

# MANISCOPIC

# MLT 627

TURBO "COMPACT"  
*Evolution*



- Maximum lifting height : 5.50 m
- Capacity : 2700 kg
- Maximum forward reach : 3.20 m
- Torque convertor
- JSM : an «all in one» system

1) *Hydraulic controls*

2) *Forward/Reverse selection*

Forward/reverse  
shift

Lowering

Tipping

Tilting

Lifting

Roller

for the attachment function  
(movement 100 % proportional)

Roller for  
extending-retracting the boom  
(100 % proportional movements)

STANDARD OR  
LOW PROFILE CAB  
VERSIONS AVAILABLE

 **MANITOU**

# MLT 627 20" TURBO

 **Lifting capacity** .....2700 kg  
at 500 mm from forks heels.

 **Lifting height** .....5.50 m  
**Times** : unladen/loaded (in s)  
Lifting .....6.65/7.02  
Lowering .....4.88/4.87  
Boom extension .....4.8/4.85  
Boom retraction .....3.02/3.34  
Time unladen (in s)  
Crowd .....3.16  
Dump .....2.99

 **Tyres**  
400/70-20 T37

 **Forks** (mm)  
Length .....1200  
Width .....125  
Carriage rotation .....154°

 **Oil bath multidisc brakes on front/rear axle**

 **Perkins engine STAGE III A**  
Type .....1104 D 44 T  
Cylinders .....4 cyl./4400 cm<sup>3</sup>  
Power (ISO/TR 14396) .....101 HP/74.5 kw  
Maximum torque .....392 Nm at 1400 tr/mn  
Direct injection  
Water cooling

 **Transmission** .....Torque Converter  
Electro - hydraulic reversing shift  
4 speeds forward and reverse  
Maximum travel speed up to .....28 km/h\*

 **Hydraulics**  
Lifting/tilting pump:  
gear type .....100 l./mn - 260 bars  
Monolever **J.S.M (Joystick Switch and Move)**  
Flow divider with priority to steering

 **Capacities**  
Cooling system .....25 l.  
Engine oil .....8.5 l.  
Hydraulic oil .....98 l.  
Transmission oil .....14.5 l.  
Fuel tank .....104 l.

 **Weight unladen** (with forks) : .....5935 kg  
**Overall width** .....2.01 m  
**Overall height**  
MLT 627 T compact .....2.06 m  
MLT 627 T .....2.21 m  
**Turning radius** (outside wheels) .....3.60 m  
**Overall length** .....4.69 m  
**Ground clearance** .....0.36 m  
**Drawbar pull** :  
MLT 627 T/MLT 627 T compact .....7100 daN

## "TAILOR MADE" DIMENSIONS

Overall width : 2.01 m  
Overall length : 4.69 m

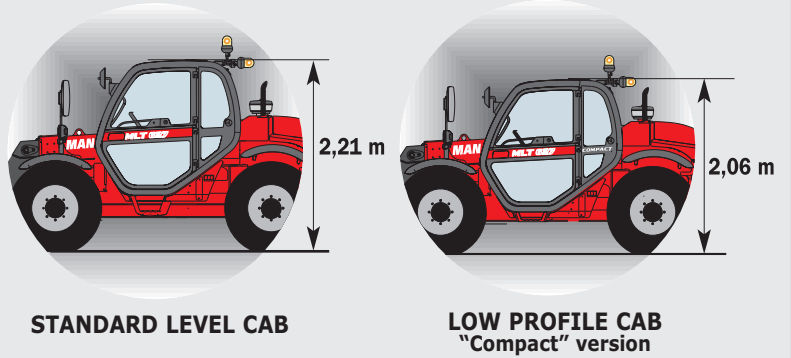

## Reach at maximum height : 0,90 m

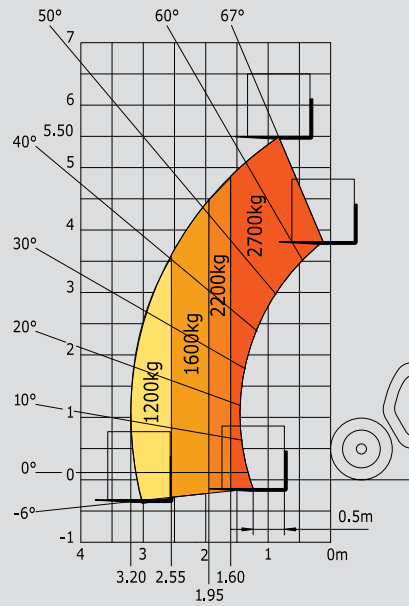

Under EN 1459 annexe B

	MLT 627 T 20" compact
A	1200
B	2520
C	1307
C1	1260
D	4687
D1	4640
D2	3925
E	5887
F	1600
G	400
I	860
J	866
K	1260
L	45
O	125
P2	41°
P3	39°
R	3385
S	7356
T	3520
U1	2210
U2	2470
V	4770
V1	1250
V2	3589
W	2007
Y	11,8°
Z	142,3°

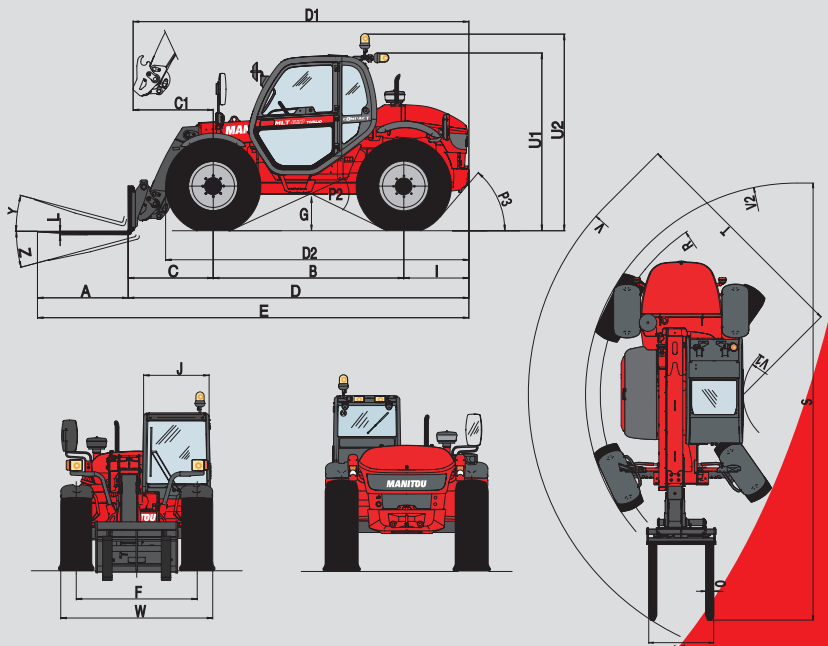

This publication in no way constitutes an offer and the company reserves the right to alter specification without prior notice.  
The MANITOU models presented in this brochure can be supplied complete with optional equipment attachments.  
Operator shall conform with applicable regulation.  
\* Can change according to the local regulation.

