

B40D_{6x4} SUPER TRUCK



key features

- Gross Power 315 kW (422 hp)
- Rated payload 36 000 kg (79,380 lbs)
- Max speed 63 km/h (39,3 mph)



D SERIES

B40D_{6x4} SUPER TRUCK

ENGINE

Configuration	Mercedes Benz OM501LA V-6
Aspiration	Turbocharged and intercooled
Cooling System	Liquid cooled with single pass radiator as well as charge air cooler
Gross power	315 kW (422 hp) @ 1 800 rpm SAE J1349
Net Power	308 kW (413 hp) @ 1 800 rpm
Gross torque	2 000 Nm (1,473 lbf) @ 1 080 rpm SAE J1349
Net Torque	1 974 Nm (1,453 lbf) @ 1 080 rpm
Displacement	11,95 litres (730 cu.in)
Fuel tank capacity	485 / (128 US gal)

TRANSMISSION

Layout	Allison HD 4560 with integral retarder & dual shifting programme																					
Gear layout	Engine mounted box with rear output Constant meshing planetary gears, clutch operated																					
Gears	6 Forward, 1 Reverse																					
Clutch type	Hydraulically operated multi-disc																					
Control type	Electronic																					
Torque converter layout	Hydrodynamic, with lock-up in all gears																					
Vehicle speeds	<table> <tr> <td>1st</td> <td>2nd</td> <td>3rd</td> <td>4th</td> <td>5th</td> <td>6th</td> <td>R</td> </tr> <tr> <td>9,1</td> <td>19,3</td> <td>28,0</td> <td>43,0</td> <td>56,0</td> <td>63,0</td> <td>8,0 km/h</td> </tr> <tr> <td>5.7</td> <td>12.5</td> <td>17.5</td> <td>27.0</td> <td>35.0</td> <td>39.3</td> <td>5.0 mph</td> </tr> </table>	1 st	2 nd	3 rd	4 th	5 th	6 th	R	9,1	19,3	28,0	43,0	56,0	63,0	8,0 km/h	5.7	12.5	17.5	27.0	35.0	39.3	5.0 mph
1 st	2 nd	3 rd	4 th	5 th	6 th	R																
9,1	19,3	28,0	43,0	56,0	63,0	8,0 km/h																
5.7	12.5	17.5	27.0	35.0	39.3	5.0 mph																

TRANSFER CASE

Layout	VGR 17000 Three in-line helical gears
--------	---------------------------------------

AXLES

Differential type	Bell 25 tonne Spiral bevel type with Controlled Traction Differentials (CTD) on front and middle axle
Final drive type	Outboard heavy duty planetary on front and middle axle
Housing type	Steel fabricated

BRAKING SYSTEM

SERVICE BRAKE	Dual circuit, full hydraulic actuation vented dry disc caliper brakes on all three axles
Maximum brake force	193 kN (43,390 lbf)
PARK & EMERGENCY	Spring applied, air released driveline- mounted disc.
Maximum brake force	440 kN (98,920 lbf)
AUXILLIARY BRAKE	Automatic exhaust brake and Engine Valve Brake (EVB)
Maximum Retardation	830 kW (1,113 hp)

WHEELS

Tyre	Size	26.5R25
	Type	Radial Earthmover
Max ground pressure (laden)		156 kPa (23 psi)

SUSPENSION

Front type	Semi-independent leading A-frame supported by nitrogen/oil struts
Rear type	Pivoting walking beams equalize the load on each axle with laminated suspension blocks. Each axle is coupled to the chassis by a Tri-Link system of three rubber-bushed links for ideal vertical movement and a transverse link for lateral restraint

HYDRAULIC SYSTEM

	Full load sensing system serving the prioritized steering, body tipping and brake functions. A ground-driven, load sensing emergency steering pump is integrated into the main system
Pump Type	Variable displacement, loadsensing piston
Application	Steering, tipping, hydraulic brake charging and cooling fan drive
Flow:	300 /min (79.26 US gal/min)
Pressure:	25 MPa (3,626 psi)
Filter:	10 micron

PNEUMATIC SYSTEM

	Air drier with heater and integral unloader valve, serving park brake and auxiliary functions
System pressure	810 kPa (117 psi)

ELECTRICAL SYSTEM

Voltage	24 V
Battery type	Two maintenance free permanently sealed
Battery capacity	2 x 105 Ah (optional 2 extra batteries)
Alternator rating	28 V 100 A

STEERING SYSTEM

	Hydrostatically actuated by two double acting cylinders, with ground-driven emergency steering pump.
Angle	+ - 42 degrees
Lock to lock turns	4,7

BODY

Capacity:	Struck	16,9 m ³ (22.1 cu.yd)
Heaped	SAE 2:1	22,5 m ³ (29.4 cu.yd)
	SAE 1:1	27,4 m ³ (35.8 cu.yd ³)
Rated payload		36 000 kg (79,380 lbs)
Raise time		13 s
Power down time		7,6 s
Tipping angle		70 degrees

OPERATING WEIGHTS

Empty:	Front	13 692 kg (30,186 lbs)
	Middle	7 257 kg (16,594 lbs)
	Rear	6 767 kg (14,919 lbs)
	Total	27 986 kg (61,699 lbs)
Laden:	Front	18 272 kg (40,289 lbs)
	Middle	23 237 kg (51,237 lbs)
	Rear	22 477 kg (49,562 lbs)
	Total	63 986 kg (141,088 lbs)

STANDARD EQUIPMENT

Cab	ROPS/FOPS certification Protective rear window guard • Handrails on fenders • Tilt cab for service access • Gas strut supported door • Tinted safety glass • Sliding windows • Rearview mirrors- regular and wide angle • Electric adjust and heated mirrors (one per side) • Sun visor • Wiper/washer with intermittent control • Tilt and telescoping steering wheel • Adjustable, air suspension seat with retractable seat belt • Fold-away trainer seat with retractable seat belt • HVAC climate control system with filtered and ducted air
Retarder	Integral transmission output retarder with 6 settings
Brakes	Vented dry disc callipers on all three axles Fully hydraulically actuated • Spring applied air release park brake on rear driveshaft
Other	Ground driven emergency steering • mechanical autogate

OPTIONAL EQUIPMENT

	(Factory and field installed) Exhaust body heating • Groeneveld central lubrication system • Body liners • Flashing beacon • Work lights • Artic reverse light • Electrical horn • 2 extra batteries • Fuel filter heating element • High speed compound tyre
Provision for:	FM and 2-way radios • Reverse camera and alarm • Wiggins quick fuelling system

B40D_{6x4} SUPER TRUCK

GRADEABILITY/RIMPULL

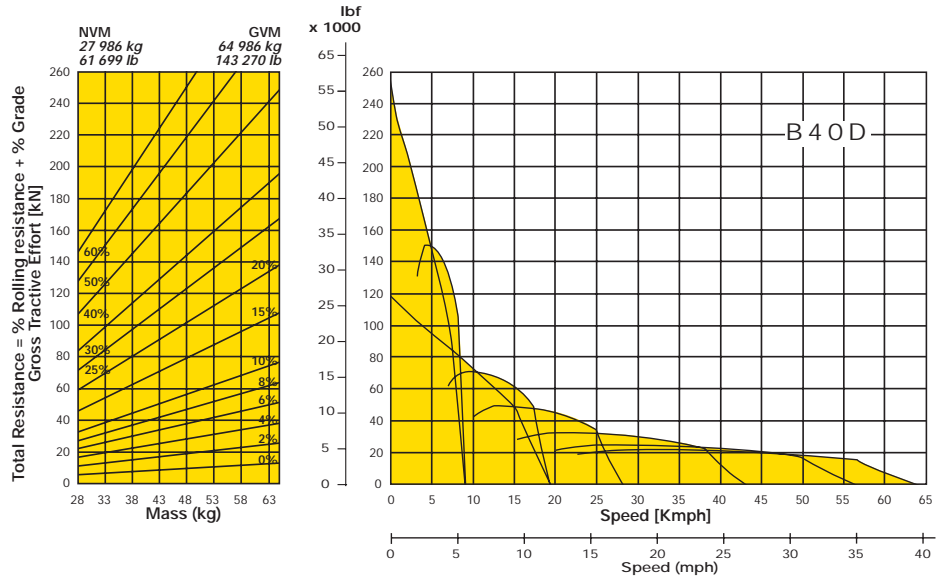

RETARDATION

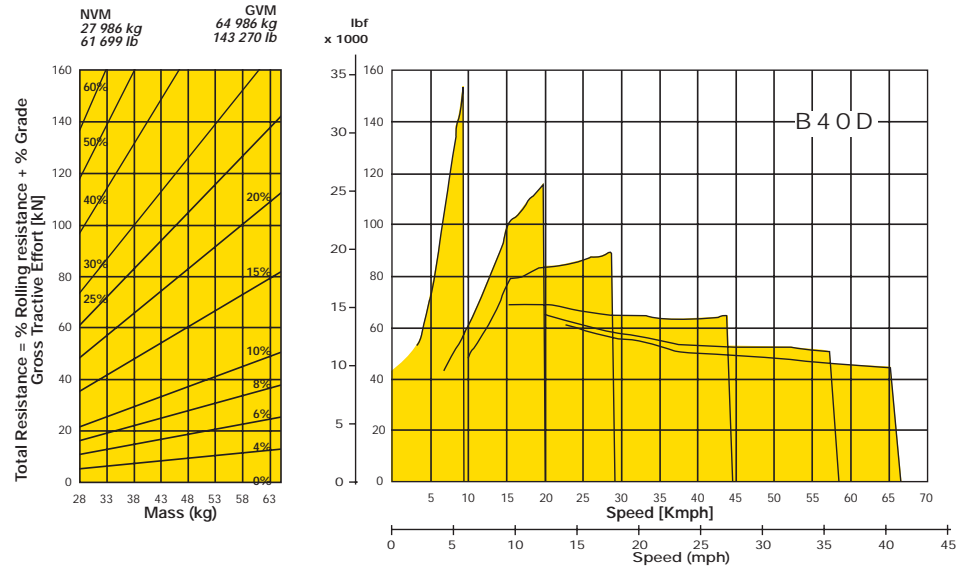

LINE DRAWING

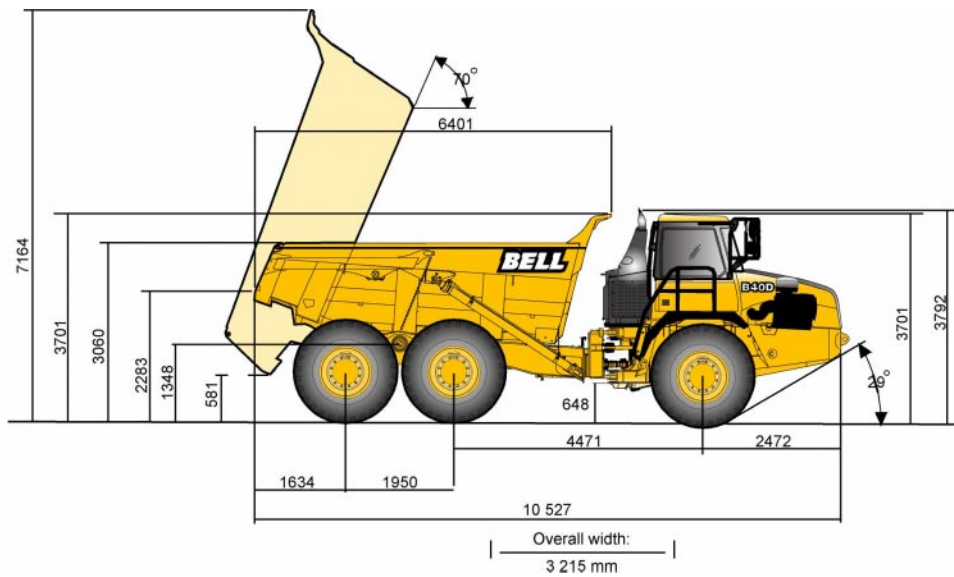

B40D^{6x4} SUPER TRUCK

LINE DRAWING

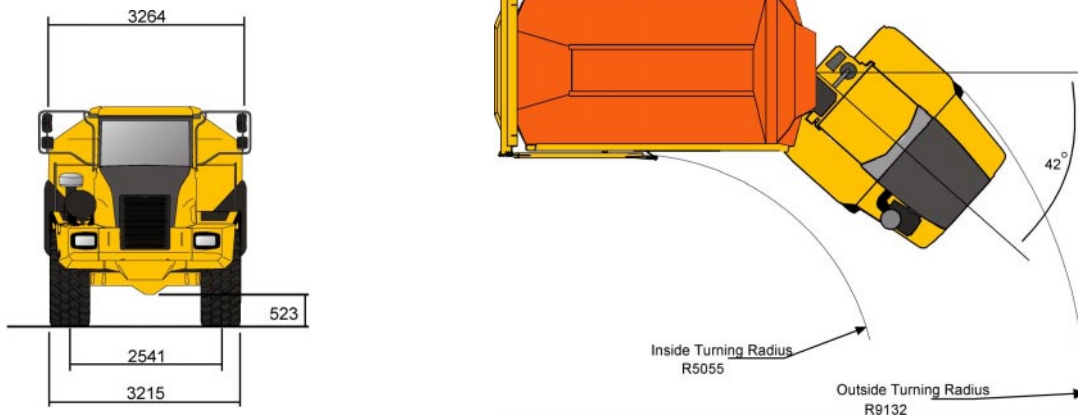

What makes the B40D Super Truck a great performer...

- High speed
- High performance engine with increased power and torque
- Improved cab - setting new standards in comfort, sound levels and simplicity in operation
- Tailgate fitted as standard
- Increased pay load
- Improved tip cycles
- Tighter turning circle
- Fewer scheduled service requirements
- Improved service access
- Electronic component protection
- Powerful hydraulic transmission retarder drastically cuts brake use extending pad life up to a factor of five
- Rops/Fops certified

BELL SOUTH AFRICA : Tel: +27 (0)11-928 9700 • Fax: +27 (0)11-928 9702
BELL INTERNATIONAL : Tel: +27 (0)35-907 9431 • Fax: +27 (0)35-797 4336
E-mail: sales@bellequipment.com • www.bellequipment.com

All dimensions are shown in millimetres, unless otherwise stated between brackets. Under our policy of continuous improvement, we reserve the right to change specifications and design without prior notice. Photographs featured in this brochure may include optional equipment.

**Strong Reliable Machines
Strong Reliable Support**

