

ATLAS Teamwork: ATLAS Teamwork:

AR 35/35 Super



Operation weight 2500 kg / 2875 kg
 Power 24.6 kW (33.5 HP) / 29.4 kW (40 HP)
 Shovel capacity 0.34 m³ - 0.40 m³

AR 40



Operation weight 3300 kg
 Power 29.4 kW (40 HP)
 Shovel capacity 0.50 m³

AR 50



Operation weight 3950 kg
 Power 42 kW (57 HP)
 Shovel capacity 0.70 m³

AR 60



Operation weight 4650 kg
 Power 47.5 kW (65 HP)
 Shovel capacity 0.85 m³

AR 65 Super



Operation weight 4700 kg
 Power 51.3 kW (70 HP)
 Shovel capacity 0.80 - 1.00 m³

AR 75



Operation weight 5600 kg
 Power 55 kW (75 HP)
 Shovel capacity 1.00 m³

AR 75 S



Operation weight 6000 kg
 Power 55 kW (75 HP)
 Shovel capacity 0.80 m³

AR 75 T



AR 80



Operation weight 5750 kg
 Power 59.3 kW (81 HP)
 Shovel capacity 1.00 m³

AR 85



Operation weight 6700 kg
 Power 71.2 kW (97 HP)
 Shovel capacity 1.30 m³

AR 95/95 Super



Operation weight 6000 kg
 Power 55 kW (75 HP)
 Shovel capacity 1.00 m³

AR 95/95 Super



Operation weight 7900 kg / 8100 kg
 Power 74.9 kW (102 HP) / 92 kW (125 HP)
 Shovel capacity 1.40 - 1.60 m³

AR 95 Super



- Construction trade, recycling, material handling, civil engineering works and road construction
- Operating weight: 8100 kg
- Power: 92 kW

TECHNICAL DATA AR 95 Super

Engine

Make:	Deutz Diesel engine
Type:	TCD 2012 L04 2V (EMR****)
Power**:	water cooled 92 kW (125 hp) at 2100 min ⁻¹
Max. torque:	520 Nm at 1600 min ⁻¹
Stroke:	4040 cm ³
Cylinders:	4 in line
Electrical System:	Operating voltage 12V Battery 12V/ 100 Ah Alternator 14V/95 A Starter 12V/3.1 kW

Drive

- Output regulated hydrostatic drive with pressure cut off and closed circuit acting on all 4 wheels.
- Speed with standard tires:
Operating speed range 0–6,5 km/h
Road speed range 0–20 km/h
Optional high speed 0–40 km/h
- 1st and 2nd hydraulic gear under load, forward/backward travel also
- Forward/backward travel and speed ranges operational via ATLAS joystick
- Drive operated by accelerator and separate inching pedal for best distribution of the hydraulic power for thrust and lifting forces.

Axles

Rigid axles with planetary reduction gears in wheel hubs, electrically connecting 100% - differential lock in front and axle.

Brakes

Standard brake Multi-disc brake in oil bath acting on all 4 wheels. Supplementary brake function via inching pedal and hydrostatic drive acting on all 4 wheels.

Parking brake Parking brake as spring-loaded brake acting on all 4 wheels. In case of standstill of engine the spring-loaded brake is automatically re-activated.

Steering

- Fully hydraulic center pivot steering
- Front and rear wheels follow the same track
- Steering angle 40° to each side, ± 12° angular movement in rear of vehicle
- Operating pressure of steering hydraulics 175 bar
- Emergency steering function

Hydraulic system

- Gear pump for loading and steering hydraulics
- Priority valve favoring steering hydraulics
- Lowering brake dependent on load
- 3rd section serial
- Loading hydraulic hydraulically pre-activated via Atlas joystick including float position
- Operating pressure 240 bar
- Delivery of pump 117.5 l/min

Loading equipment

- Powerful and solid Z-kinematics with high tear out force
- Hydraulic quick exchange device. Activation of all functions via ATLAS joystick. Parallel movement while using pallet forks
- Automatic shovel return to excavation position
- Locking device for travel on road
- Automatic center position

Lifting	5.7 s
Lowering	4.6 s
Tipping	1.7 s

Standard equipment

- ATLAS diagnostic system (ADS) for monitoring the engine parameters with integrated electronic anti-theft device
- Rear driving mirrors, foldable
- Heatable rear screen
- Comfortable access to cab from both sides
- Single lever operation via ATLAS joystick
- Control lights for speed range, forward/backward travel
- Lights acc. to StVZO
- Individually adjustable driver's seat with adjustable right arm rest
- Hot water heating with heat exchange and 4-stage fan
- Front windscreen ventilation, variable output
- Sound absorbing ROPS cab
- Windscreen wipe and wash unit in front and rear
- Sun visor, coat hook, ceiling lamp, stow facility
- Adjustable steering column
- Heat protection glazing with large tinted screens
- Control lights for engine oil pressure, overheating, hydraulic oil temperature, battery power, parking brake, air filter
- Central dashboard with indicators for preheating, engine temperature, fuel, working hour meter

Options

- 4th section front or rear
- Stability dumping system
- Slow drive inching pedal
- High speed version
- Extended lifting frame
- Hand throttle device
- Final position damper for working cylinder
- Trailer coupling
- Main battery switch
- Corrosion protection for salt

- Special colors and oils
- Load check valve for lifting and working cylinders
- Heatable and air cushioned seats
- Joystick with integrated proportional steering for 3rd section
- Air conditioning, auxiliary heating
- Radio
- Warning beacon
- Doors with sliding windows left and right
- Anti-theft device with code stick

More options upon request

Tires

Standard: 15.5-25 EM – Construction machine tires for relatively soft surfaces with high traction and good self-cleaning

Special tires: 460/70 R 24 XMCL – Construction machine tires for clay, sand, gravel, greenland, fields and fortified roads
455/70 R 24 SPT 9 – Construction machine tires for clay, sand, gravel, fortified roads, gardening and landscaping

More special tires upon request

Fuel/oil capacities

Diesel:	120 l
Hydraulic oil:	106 l
Engine oil:	9.5 l
Front axle:	7.2 l
Rear axle:	7.2 l
Gear oil:	1.8 l
Cooling liquid:	15 l

Operating data

Shovel capacity acc. to SAE:	1.4 - 1.6 m ³
Track width:	1770 mm
Turning radius (outer shovel edge):	5005 mm
Tear out force:	7200 daN
Torque:	6900 daN
Tipping load, straight:	6700 kg
Tipping load, articulated:	5965 kg
Lifting capacity at ground level:	8200 daN
Service weight:	8100 kg

Differing data for use of pallet forks (500 mm distance to center of gravity)*

Static tipping load, straight and articulated:	4755 kg
Lifting capacity:	6800 daN
Payload 80% even surface**:	3804 kg
Payload 60% uneven surface**:	2853 kg

Sound level

Average acoustic power-level L _w A ⁽¹⁾ :	102.0 dB (A)
Guaranteed acoustic power-level L _w A ⁽²⁾ :	103.0 dB (A)
Sound pressure level L _p A ⁽³⁾ :	79.0 dB (A)

Specific vibration-data
Hand-/arm-/body-vibration⁽⁴⁾: < 2.5 / 0.5 m/s²

* Travel with load only permitted close to the ground.

** According to ISO 8313 and EN 474-3

*** According to ISO 14396, EU RL97/68/EC.

**** Electronic control unit.

(1) According to 2000/14/EG & appendixes.

(2) According to 2000/14/EG & appendixes.

(3) According to ISO 6396.

(4) According to ISO 8041.

Specific gravity for material handling

material	weight (t/m ³)
concrete	1.9
soil (dry)	1.5
soil (watery)	2.0
rock (fill)	2.4
granite	1.8
limestone	1.6
gravel (dry)	1.9
gravel (watery)	2.1
loam	1.7
plaster	2.2
sand (dry)	1.9
sand (watery)	2.1
sandstone	2.4
shale	2.2
sediment	2.1
crushed stone	1.5
de-icing salt	1.3
clay	1.6
cement	1.7
clinker (stacked)	1.8

Industry

ember	0.7
brown coal briquette	0.8
ferrous product	7.8
iron ore	2.3
cullet	1.9
gas coke	0.4
timber	0.8
mineral coal	1.2
paper	0.9
slag	1.0
slag concrete	2.7

Landscaping, agriculture

agricultural crop	0.7
grain	0.6
hay	0.3
potash	1.1
compost	1.0
flour	0.5
clay (watery)	2.3
phosphate fertilizer	2.2
turf (watery)	1.1
turf (dry)	0.4
mineral fertiliser	1.0

Technical data with standard shovel.

AR 95 Super

A	6230
B	2932
B ₁	2165
C	4575
C ₁	3630
C ₂	2840
D	85
E	820
F	540
G	2500
H	2180
I	2300
R	2385
R ₁	4610

All specifications in mm

α	40°
---	-----

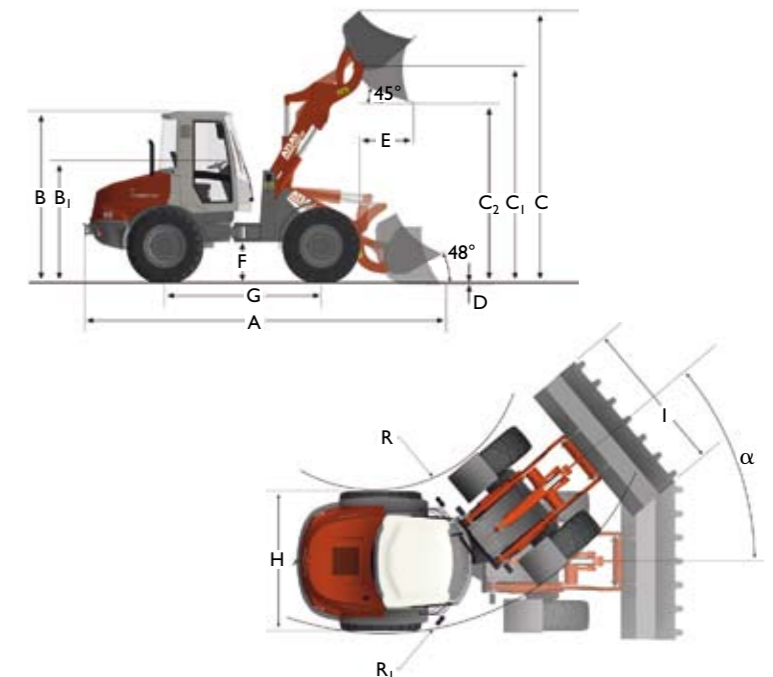

Technical data with pallet forks.

AR 95 Super

A	6550
B	2932
B ₁	2165
C	4025
C ₁	3430
C ₂	1650
D	70
E	550
E ₁	1270
E ₂	700
F	540
G	2500
H	2180
I	1400
R	2385
R ₁	4610

All specifications in mm

α	40°
---	-----

