

TH340B

Telehandler



Cat® 3054E Diesel Engine

Gross Power

74.5 kW/99.9 hp

Operating Weight

7700 kg

Rated Load Capacity

3000 kg

Maximum Lift Height

9500 mm

TH340B Telehandler

Caterpillar Telehandlers offer performance and versatility.

Operator Station

- ✓ Operators will feel relaxed and comfortable in the spacious, ergonomically designed cab.

Considerable attention has been paid to control layout, making this cab an industry leader. **pg. 4**

Ease of Operation

- ✓ Ease of operation was paramount in the design of the new TH340B. The single joystick, with its intuitive, modulated, hydraulic functions and the new Cat® electronic machine information display are designed to maximize operator efficiency. **pg. 5**

Performance

- ✓ In its size class, the TH340B combines productivity, maneuverability and responsiveness to deliver smooth and stable performance on the job site. **pg. 6**

The TH340B is a highly versatile machine, designed to deliver maximum performance with traditional Cat reliability, durability and productivity in the toughest working conditions.



✓ *New features*

Powertrain

- ✓ The TH340B is designed to perform in the toughest conditions. With its Caterpillar 3054E engine and purpose designed Caterpillar transmission and axles, you can depend on the TH340B to keep your job on schedule. **pg. 7**

Versatility

- ✓ The TH340B is a very versatile machine. With its optional hydraulic quick coupler and extensive range of work tools, you can simply and efficiently get the job done. **pg. 8**

Cost of Ownership

- ✓ Extended service intervals and the reduction in service parts give Cat the lowest operating costs in the industry. **pg. 9**

Serviceability and Customer Support

- ✓ The lowest operating costs in the industry – setting new standards in serviceability.
Caterpillar Dealer Services enables you to operate longer with lower costs, helped by significantly extended service intervals. **pg. 10**



Operator Station

The operator station provides comfort and protection with excellent job site visibility and convenient, logical controls.



Intuitive Control Layout. All day operator comfort and efficiency is ensured through our simple, logical control layout.

Electronic Machine Information Display. Communicates essential technical data to facilitate easier machine operation.

Joystick. The joystick is capable of three simultaneous boom functions making machine operation easy. All functions are fully modulated.

Easy Access. Cab entry and exit is both easy and safe due to the well placed handholds and step.

Operator Protection. The machine provides full operator security with ROPS/FOPS protection.

Seat. A variety of seats are available, tailored to meet the requirements of the operator and applications.



Excellent Visibility. The B Series cab has superb visibility due to the use of advanced virtual design techniques.

Ease of Operation

Ease of operation was paramount in the design of the new TH340B. The single joystick, with its intuitive, modulated, hydraulic functions and the new Cat electronic machine information display are designed to maximize operator efficiency.



Joystick Control. The joystick allows three simultaneous boom functions and incorporates a unique slider switch. Two joystick control patterns are available to meet application requirements. The joystick also operates the auxiliary hydraulic function and allows the option of a second auxiliary service for the use of work tools that require more than one hydraulic service.

Hydraulic System. The Cat Electro Hydraulic system allows all three boom functions to be operated simultaneously and proportionally. This enables precise placing of loads in challenging applications. Auxiliary hydraulic functions are available on the joystick to allow operators to utilize more complex work tools. A continuous flow auxiliary hydraulic supply is also available for operating tools such as pickup brooms.

Integrated System. Cat's exclusive integrated management system allows the engine, transmission and hydraulic systems to operate with maximum efficiency, control and productivity.

Flow Sharing. Three simultaneous hydraulic functions are achieved using a flow sharing hydraulic valve. A load sensing variable displacement pump allows full hydraulic power even at low revs.

Performance

The TH340B delivers high performance to meet your specific job site needs.



Lift Height. The TH340B can effectively and quickly place bricks, roofing materials and trusses to a maximum height of 9500 mm.

Reach. Job site obstacles present challenges demanding a machine to place loads at greater distances – the TH340B delivers.

Maneuverability. The TH340B offers excellent maneuverability, due to its tight turning circle and its three different steering modes. The TH340B has 48 degree axle turning circle and no rear tail swing, allowing it to work productively and safely in confined areas.

Steering Modes. The TH340B offers three steering modes (two wheel, crab and circle steer) to allow an operator to easily position the machine. Steering modes are selected by a single 3-position rocker switch.

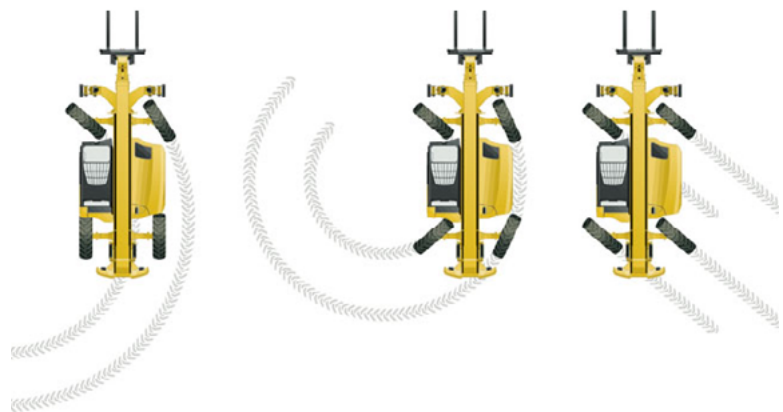

Powertrain

Caterpillar engines, axles and transmissions give you the quality powertrain that you expect.



High Torque Rise Engine.

The Cat 3054E Electronic engine is fully compliant with the latest round of worldwide emissions regulations. While continuing to deliver maximum performance, they also feature improved timing, reduced smoke and exceptional service improvement. For improved sound characteristics, a venturi tailpipe has been packaged inside the engine enclosure.

Electronic engine delivers:

- Improved low idle performance
- Product Link capabilities
- Improved fuel consumption
- Increase diagnostic and security capability

Cooling System. The cooling system has been designed to work in the most challenging conditions.

Transmission. The B-Series has a purpose designed Cat transmission. The TH340B is available with a power shuttle transmission. For improved operator efficiency, a Cat designed four speed forward/three speed reverse powersyncro transmission is available.

Axles. The TH340B is fitted with Caterpillar planetary reduction axles, with four wheel braking. For improved machine performance in difficult conditions, a differential lock is available (front axle).

Versatility

Re-define the traditional role of a Telehandler with the Cat TH340B.



Hydraulic Services. Machines can be equipped with Auxiliary Hydraulic services, allowing the use of hydraulically operated work tools. 3 options are available:

- One auxiliary hydraulic service at the boom head
- Two auxiliary hydraulic services at the boom head
- Continuous Hydraulic Flow

These auxiliary hydraulic services are available as an option on the B Series through the Merchandising Arrangement (MA) structure.

Quick Coupler. An IT interface is standard on the B Series. It is available in both a manual and a hydraulic version.

For optimum versatility, machines can be equipped with the hydraulic quick coupler, allowing the operator to quickly and easily change work tools without leaving the cab.

Tow Hitches. A range of Tow Hitches are available to meet local market regulations. All Cat Telehandler models come with an ISO10532 rated retrieval point as standard.

Work Tools. A wide range of work tools are available to meet most job site applications. Caterpillar Telehandler Work Tools extend the versatility of the machine. Built for performance and durability, these work tools deliver high productivity, long life and excellent value.

- General Purpose Bucket (1.0 m³)
- Material Handling Bucket (1.5 m³)
- Multi Purpose Bucket (1.0 m³)
- Grapple Bucket (0.85 m³)
- Fixed Carriage
- Rotate Carriage
- Sideshift Carriage
- Wide Carriage
- Wide Rotate Carriage
- Pallet Forks
- Extended Shank Forks
- Block Forks
- Lift Hook
- Truss Boom
- Self-tipping Hopper
- Material Handling Arm
- Pickup Broom



Cost of Ownership

Specifically designed to lower your owning and operating costs.

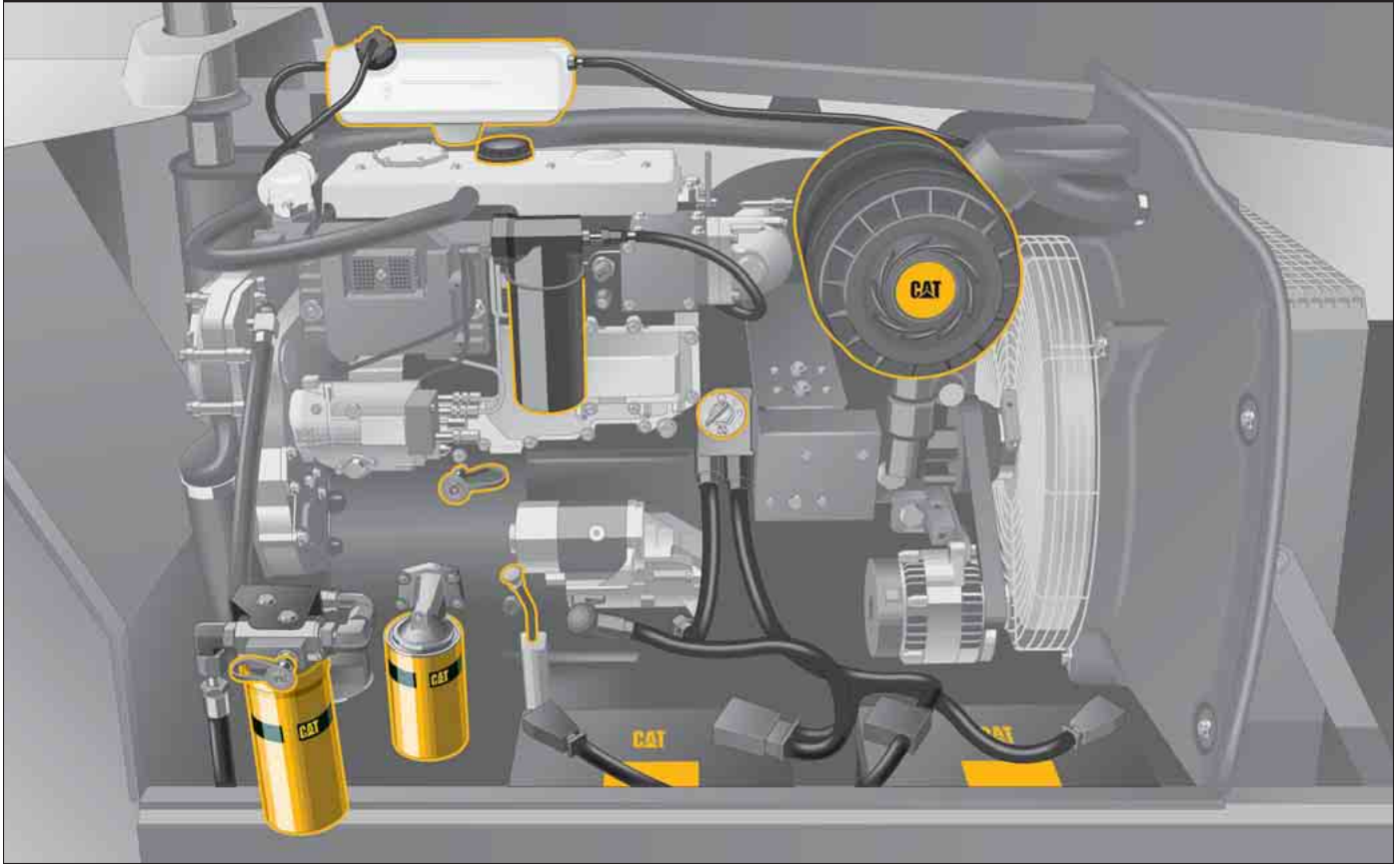

Ease of Access. Cost of ownership starts with ease of service. All Cat Telehandler service points are readily accessible and major components are easy to reach at ground level due to overall machine design.

Daily Maintenance. Routine daily maintenance is now reduced to checking fluid levels and a walkaround inspection.

Service Intervals. Engine oil, filter changes and routine lubrication are now only required every 500 hours.

Reduced Componentry. The combined hydraulic/transmission oil filter requires changing at 1000 hours. With the reduction in the number of filters and extended service intervals, owning and operating costs are the lowest in the industry.

Machine Security System. Secure your investment with Caterpillar's Machine Security System (MSS), a programmable key system that provides maximum machine security for Cat Telehandler owners.

- MSS disables machine by interacting with the machine's Electronic Control Modules (ECM)
- Keys fit all existing Cat machines (including machines without MSS)
- Each machine can store up to 50 key identifications
- Each key can be configured to operate a certain range of machines or enable operation for a certain period of time

Serviceability and Customer Support

Caterpillar Dealer Services enables you to operate longer with lower costs, helped by significantly extended service intervals.



Access. All Cat Telehandler service points, including the combined transmission/hydraulic oil filter, are readily accessible and major components are easy to reach at ground level due to the overall machine design. A cab mounted service point allows access to the fuel fill, hydraulic oil fill, washer bottle, fuse box and cab air filter for daily checks.

Selection. Make detailed comparisons before you buy. Your Cat Dealer can give you precise answers to these questions.

Purchase. Look at the value that the TH340B Telehandler will offer you. Consider all the flexible financing options your Cat Dealer offers as well as day to day operating costs.

Operation. Improving operating techniques can boost your profits. Your Cat Dealer has training literature and other ideas to help increase your productivity.

Maintenance. Repair options guarantee the cost of repairs up front. Diagnostic programs such as Scheduled Oil Sampling and Technical Analysis help you avoid unscheduled repairs.

Replacement. Repair, rebuild or replace? Your Cat Dealer can help you evaluate the cost involved so you can make the right choice.

Product Support. You will find high availability of parts at our Dealer parts counter. Cat Dealers utilize a worldwide computer network to find in-stock parts to minimize machine downtime.

Easy Financing. Your Cat Dealer can provide a financing package to meet your needs.

Product Link. This established Caterpillar technology uses a Global Positioning System (GPS) to provide additional machine data to both Cat dealers and end users. Data can be received by either a web based application system or notifications by email or pager. Product Link can provide:

- Machine hours
- Location four times a day
- Notifications via email or pager
- Total fuel consumption
- Events and diagnostics from data link

Cat Engine 3054E

Ratings at 2200 rpm

Gross Power	74.5 kW/99.9 hp
Maximum Net Power	
ISO 9249	73.1 kW/97.9 hp
EEC 80/1269	73.1 kW/97.9 hp
Maximum Torque at 1400 rpm	410 Nm
Bore	105 mm
Stroke	127 mm
Displacement	4.4 liters

- Maximum net power shown is the power available at the flywheel when the engine is equipped with fan, air cleaner, muffler and alternator.
- Engine meets EU directive 97/68/EC Stage II emissions requirements.

Boom Performance

	seconds
Boom Up	8
Boom Down	6
Tele In	10
Tele Out	8
Crowd Forward (dump)	3
Crowd Backward	3
Combined	
Up and Out	16
Down and In	16

Hydraulic System

Maximum System Pressure	250 bar
Maximum Pump Flow	113 L/min
Auxiliary Hydraulic Supply	
Continuous	60 L/min
Intermittent	90 L/min
Pump Type	
Variable Displacement Load Sensing	
Axial Piston Pump	

Brakes

Service Brake	Servo assisted on front axle
Parking Brake	Dry disc on front axle

Operating Specifications

Rated Load Capacity	3000 kg
Maximum Lift Height	9500 mm
Load at Maximum Height	2000 kg
Maximum Forward Reach	6500 mm
Load at Maximum Reach	600 kg
Top Travel Speed	32 km/h
Operating Weight	7700 kg

Service Refill Capacities

Fuel Tank	115 liters
Hydraulic Tank	60 liters

Transmission Speeds

	km/h
Forward	
1	6
2	12
3	20
4	32
Reverse	
1	6
2	12
3	20

Sound

Operator Sound. The operator sound level measured according to the procedures specified in ISO 6396 is 80 dB(A).

Exterior Sound. The labeled spectator sound power level measured according to the test procedures and conditions specified in 2000/14/EC is 106 dB(A).

Tires

Standard	13.00-24
----------	----------

Load Charts and Dimensions

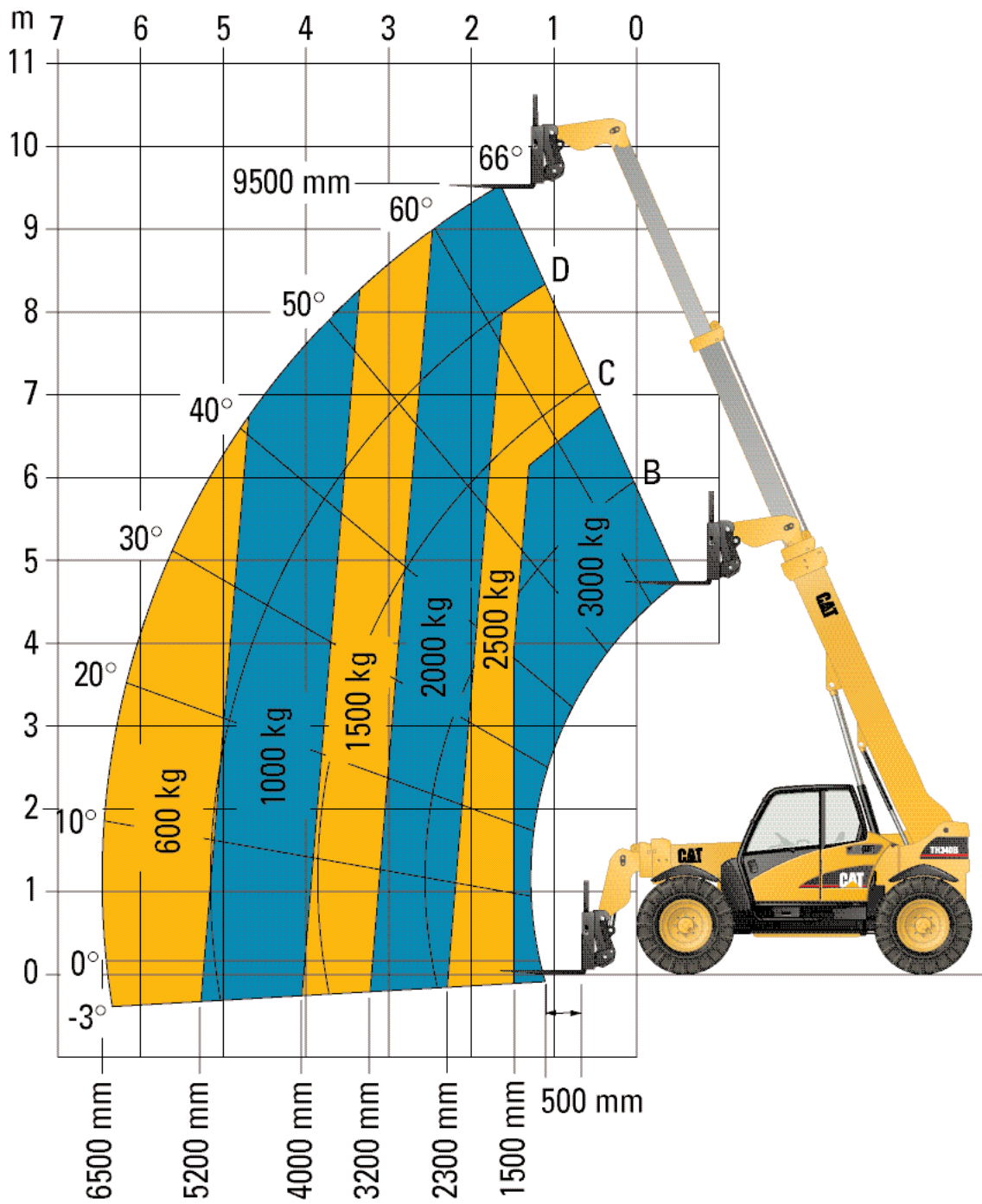

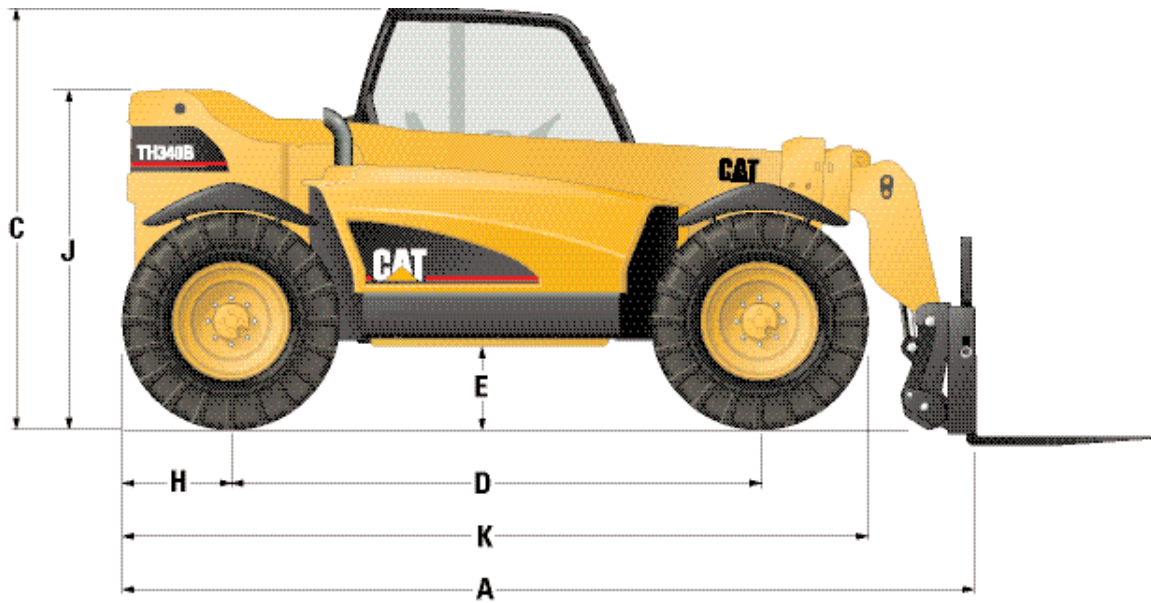

	mm
A Length to Carriage	4950
B Width	2492
C Height	2410
D Wheelbase	3050
E Ground Clearance	498
F Track	2088
G Cab Width	900
H Rear Overhang	635
J Rear Boom Height	1938
K Length to Front of Tire	4320
Outside Turning Radius over Tires	3750
Outside Turning Radius over Forks	4700



Standard Equipment

Standard equipment may vary. Consult your Caterpillar dealer for specifics.

Telescopic Boom

Wear pads, non-metallic
Lock valve on hydraulic cylinders
Boom angle indicator

Electrical

Alternator, 105-amp
Anti-restart key switch
Battery, Maintenance-free, 12 volt,
750 CCA
Battery disconnect
Horn
Alarm, Back up
Electronic Control Module
Power Sockets, 12 volt internal
and external
'Electronic Technician'
diagnostic connection

Operator Station

Enclosed cab, ROPS/FOPS
Joystick, Electronic
Adjustable joystick wrist rest
Low step, grab bars for easy entry
2 way adjustable seat, seat belt,
document pouch
Steering wheel spinner knob
Floor mat
Right side rear view mirror
Service Door, Cab air intake filter,
fuel fill, hydraulic fill, level indicator,
fuse panel and washer fill
Instrument Cluster with:
powertrain and system monitor,
longitudinal stability indicator,
steering alignment indicator,
fuel gauge,
engine oil temperature gauge,
engine water temperature gauge,
hydraulic transmission temperature,
SMU and air filter blockage light
2 piece entry door
Cup holder
Fixed Steering Column

Powertrain

Engine, Caterpillar 3054E
Air cleaner; Dual element and filter
condition indicator
Thermal starting aid
Water separator
Transmission, Caterpillar 4 forward/
3 reverse powershuttle
Direction change, single lever,
column mounted
Spin-on filters; engine oil filter,
hydraulic/transmission filter
Axles, Caterpillar; planetary drive,
full time mechanical 4-wheel drive,
Integrated steer cylinders protected
above axles
Steering, power assisted, enclosed oil
disc brakes, front axle
Parking brake, dry disc with
transmission disconnect

Structure

Chassis, frame level
Mechanical Quick Coupler

Antifreeze

Antifreeze, extended life -37°C

Tires

Mitas Brand 13.00-24

Other Equipment

Integrated lift and tie down points
Padlock on power module
Retrieval Point
Standard Cat color paint

Optional Equipment

Optional Equipment may vary. Consult your Caterpillar dealer for details.

Telescopic Boom

Hydraulic quick coupler
Single auxiliary to the boom head
Dual auxiliary to the boom head

Electrical

Light packages; boom lights,
 roading lights, cab lights
Alternator, 105 amps
Product Link
Dual battery
7 pin trailer services socket
Engine heater block,
 240V/750 Watts

Operator Station

Canopy, ROPS/FOPS
Air conditioning
Seats; cloth suspension,
 cloth air-suspension
Headliner
Door pocket
Sun visor
Screen guard
Exterior cab lights, front and rear
Additional left hand mirror
Rear wash/wipe
Machine Security System (MSS)
Beacon, magnetic mount
Adjustable steering column
Radio ready
Auxiliary hydraulic continuous
 flow switch
Adjustable joystick armrest

Powertrain

Transmission, Caterpillar 4 speed
 powersyncro
Differential lock
Auto steering align

Anti-Freeze

Anti-freeze, extended life -50°C

Tires

13.00-24 SGG Goodyear
15.5/80-24 12PR Goodyear
15.5-25 12PR Mitas
15.5-25 SGL Goodyear
15.5-25 XTLA Michelin
460/70R IND IT520 Goodyear
17.5LR24 XM27 Michelin
15.5R25 XTLA Michelin
15.5R25 XHA Michelin

Other Equipment

Fenders
Lockable storage drawer
Custom color

Work Tools

Carriage; standard, rotate, wide frame,
 wide frame (rotate), side-shift
Forks:
 Pallet forks 45 x 100 x 1070 mm
 Pallet forks 50 x 100 x 1220 mm
 Block forks 50 x 50 x 1220 mm
 Pallet forks 50 x 100 x 1520 mm
 Extended shank forks 50 x 100 x 1220 mm

Buckets:

 General Purpose 1.0 m³
 Multi Purpose 1.0 m³, width 2450 mm
 Material Handling 1.5 m³, width 2450 mm
 Multi-grapple 0.85 m³, width 2350 mm

Material Handling Arm

Self-tipping Hopper, 1.2 m³

Lifting Hook

Truss Broom

Pick-up Broom

Other Attachments

Tow hitches; hitch, manual rear-tow
Hitches complete width adjustable
frame height:

 Hitch, tow, category "C" clevis

 Hitch, towing, manual

 Hitch, towing, auto

TH340B Telehandler

HEHB2996 (09/2003) hr

Materials and specifications are subject to change without notice.
Featured machines may include additional equipment.
See your Caterpillar dealer for available options.

www.CAT.com
© 2003 Caterpillar

CATERPILLAR[®]