



Universal
ViC17

Mini-excavator



Vi017

Operating weight : 1740 kg

Arm digging force : 870 kgf

Bucket digging force : 1550 kgf

Yanmar, inventor and leader of the ZTS mini-excavators



- Real Zero Tail Swing machine : neither the counterweight nor the front part of the upper frame exceed the width of the crawlers.
- Possibility to work along a wall. Safety and productivity for the operator.
- Variable undercarriage from 950 to 1280 mm : higher stability on extreme grounds.
- Extendable undercarriage of unique conception from Yanmar : clogged mud is easily pushed out thanks to sliding parts.
- Canopy fully compliant to safety norms : ROPS (Roll Over Protective Structure), FOPS 1 (Falling Object Protective Structure) and TOPS (Tip-Over Protective Structure).
- Cylinders completely protected (rod and cylinder) by highly elastic steel plates to resist any possible shocks.
- Integrated working lamp.

- Careful routing of hydraulic pipes in the center of the upper frame and on the boom : perfect protection.
- Layout of the counterweight designed to protect the side panels against any possible shocks.
- Spacious operating position, ergonomic arm-rests and pilot system : reduced operator fatigue.
- A new-generation Yanmar engine which exceeds the most stringent emissions standards.
- Hydraulic circuit fitted with a variable flow dual piston pump and a gear pump : higher precision and possibility to combine various working movements (boom, arm, upper frame).
- Perfect combination of the Yanmar engine and the hydraulic system for reduced fuel consumption.
- Easy access to all maintenance points : engine components and hydraulic pumps...

Mini-excavator



TECHNICAL SPECIFICATIONS



Operating weight **+2%** :
1740 kg with rubber crawlers

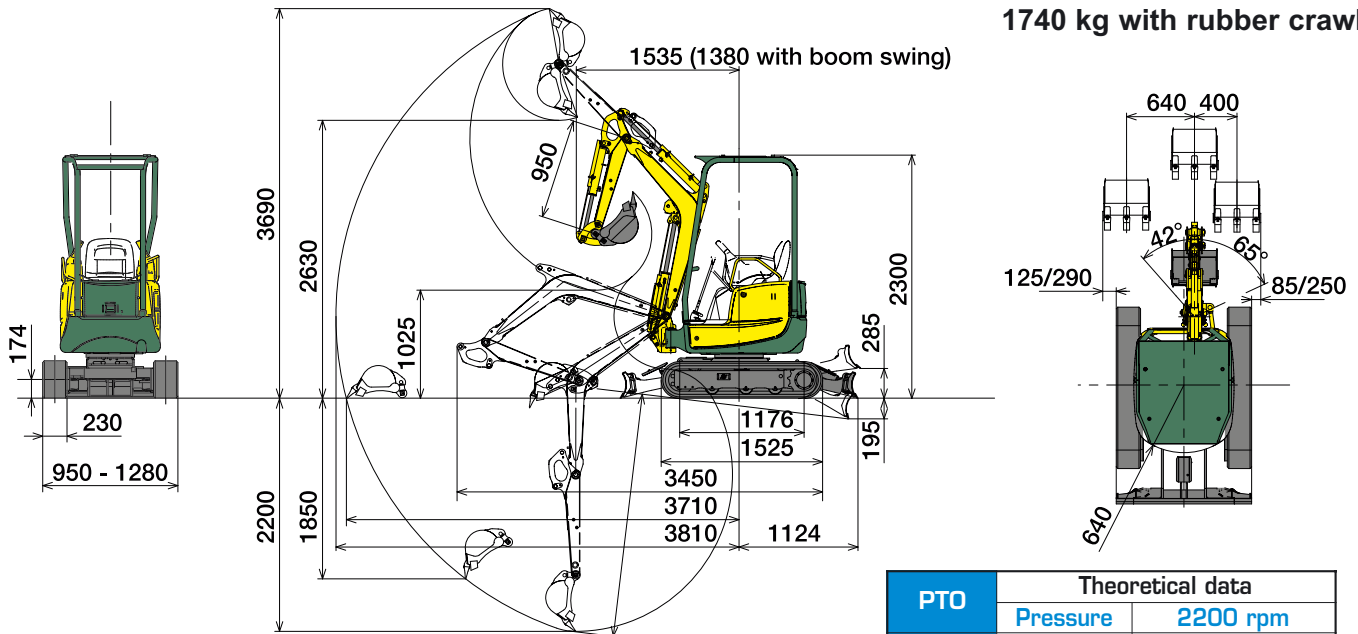

Subject to any technical modifications.
Dimensions given in mm with standard Yanmar bucket.

PTO	Theoretical data	
	Pressure	2200 rpm
	0 ~ 210 bar	30.8 ~ 0 l/mn
	0 ~ 210 bar	30.8 ~ 0 l/mn

The output reduces as the pressure increases.

Machine with canopy,
rubber crawlers,
bucket of 38 kg (400 mm).

Tipping load, rating over front

A : Overhang from rotational axis (m).
B : Height of hooking point (m).
C : Safe working load (kg).
N : Retracted undercarriage.
W : Extended undercarriage.

Tipping load, rating over side 90°

		ViO17
3-cylinder Yanmar engine	Type	3TNV70-XBV
	Rated Output (DIN 6270B)	10.1 kw/13.5 HP/2200 rpm
	Displacement	854 cm ³
Hydraulic circuit	Max. torque	47.5-51.8 N.m./1600 rpm
	System capacity	26.5 l
	Max. pressure	210 / 170 bar
Performances	Variable flow dual piston pump + gear pump	2 x 17.6 l/mn + 1 x 13.2 l/mn
	Travelling speed	2.1/4.2 km/h
	Swing speed	9.5 rpm
	Digging force (arm)	870 kgf
	Digging force (bucket)	1550 kgf
Undercarriage	Grade ability	30°
	Ground pressure	0.27 kg/cm ²
	Shoe width	230 mm
	Ground clearance	174 mm
Miscellaneous	Blade (width x height)	950/1280 x 235 mm
	Fuel tank	20 l
	Cooling system	3.2 l
Optional equipment	Transport dimensions (L x w x h)	3456 x 950 x 2292 mm
	Noise level LwA (2000/14/EC & 2005/88/EC)	93 dBA
Optional equipment	Special paint	Third circuit extension
	Standard buckets	Anti-start system
	Ditch cleaning buckets	Anti-theft device
	Swivelling buckets	

Blade on ground												
A	Maxi			2.5 m			2.0 m			Mini		
	N	W		N	W		N	W		N	W	
2	145	240	*300	210	*315	*295	-	-	*295	250	*310	-
1.5	130	220	*305	200	*370	*310	310	*420	*355	-	-	-
1	115	205	*305	185	305	*365	260	440	*480	325	555	*415
0.5	115	205	*310	175	300	*410	240	425	*575	285	505	*625
0	95	210	*320	170	285	*450	230	400	*625	290	505	*745
-0.5	135	230	*330	165	290	*435	240	400	*600	-	-	*810
-1	160	270	*325	-	-	-	235	405	*510	-	-	-

Blade above ground												
A	Maxi			2.5 m			2.0 m			Mini		
	N	W		N	W		N	W		N	W	
2	140	200	215	205	*295	*295	-	*290	*295	245	-	-
1.5	125	175	195	195	250	*310	305	*355	*350	-	*415	*410
1	115	170	185	180	250	270	255	345	375	310	430	470
0.5	115	165	180	175	245	265	235	320	365	280	390	450
0	115	175	185	170	235	260	220	310	350	280	470	525
-0.5	130	190	200	160	235	255	240	305	345	-	-	-
-1	155	230	260	-	-	-	230	320	355	-	-	-

The data contained in these tables represent the lifting capacity in accordance with ISO standard 10567.
They correspond to 75% of the maximum static tipping load or 87% of the hydraulic lifting power.
Data marked * are the hydraulic limits of the lifting power.



AMMANN-YANMAR SAS

25, rue de la Tambourine - F-52100 SAINT DIZIER

sales@ammann-yanmar.fr

www.ammann-yanmar.com



Versus Studio - Printed in France - Materials and specifications are subject to change from the manufacturer without notice. Please contact your local Ammann-Yanmar dealer for further information.