



NEW HOLLAND

L213 L215 L218 L220 L223 L225 L230
200 SERIES SKID STEER LOADERS



200
SERIES



BUILT AROUND YOU

Built Around You

No matter what your line of work—landscaping, farming or construction—you'll complete your jobs more effectively with a New Holland 200 Series skid steer loader. The New Holland product development team worked with over 1,000 valued New Holland and competitive skid steer customers for three years to develop final concepts for the 200 Series skid steer loader.

The product development team then used virtual reality technology and New Holland's Arizona proving grounds to test these concepts with prototype units and customer groups of landscapers, farmers, and general contractors.

New Holland listened and designed a skid steer loader that met the challenges, answered the requests and fulfilled every wish list. It's the skid steer loader you would want on the job – one that's durable, reliable and productive. New Holland proudly manufactures the 200 Series skid steer loader.



Rock-Solid Stability

New Holland introduced the long wheelbase concept to skid steers loaders, and now goes longer with the 200 Series. When combined with a low center of gravity and the correct front-to-rear weight distribution, the result is a smooth and stable ride.

Unmatched Dump Height and Reach

The patented New Holland Super Boom® vertical lift linkage offers more height and reach which allows operators to load material into the center of the of high-sided truck boxes or hoppers.

	MODEL	Gross Horsepower hp (kW)		Rated Operating Capacity @ 50% Tipping Weight lbs (kg)		Operating Weight lbs (kg)		Height to Hinge Pin in (mm)		DUMP REACH (Max. Height) in (mm)	
Radial Lift	L213	46	(34)	1,300	(590)	5,000	(2270)	112	(2845)	18.5	(469)
	L215	52	(39)	1,500	(680)	5,300	(2400)	112	(2845)	18.5	(469)
Super Boom® Vertical Lift	L218	60	(45)	1,800	(818)	5,930	(2690)	120	(3048)	30.8	(783)
	L220	60	(45)	2,000	(905)	6,470	(2935)	121	(3073)	29.8	(758)
	L223	74	(55)	2,250	(1020)	7,380	(3350)	129.5	(3290)	32.3	(820)
	L225	82	(61)	2,500	(1135)	7,900	(3580)	129.5	(3290)	32.3	(820)
	L230	90	(67)	3,000	(1360)	8,300	(3765)	131.1	(3330)	30.7	(780)

Superior Operator Comfort

New Holland knows that comfort is not simply a luxury: It's vital to your business. Operators who are comfortable can work longer hours with less fatigue. So, we were sure to build in extra comfort when we designed the 200 Series.

- The widest skid steer cab in the industry provides more head room and shoulder room for any size operator. The entry foot well is flat for easy entry and exit.
- The optional heated, cloth upholstered, air-ride seat gives maximum support and eliminates fatigue.
- Our ergonomically designed joysticks put all controls right at your fingertips. And we now have optional controls that are switchable - both ISO & H-Pattern.
- The air vents are strategically located to cover operator extremities as well as defrost the door and windows.
- There's more than twice the visibility as before in the critical zones based on visibility testing*.



Easy Servicing

And when it comes to service, New Holland gets it: service downtime is lost revenue and maintenance is more likely to be done when it is easy to get done.

- By simply opening the engine compartment rear door, you can easily identify service points like the engine oil fill and dipstick, the air filter, oil cooler, radiator, coolant over flow, fuel filter, and oil filter. Battery maintenance is simple, too.
- And if you need more service access, the all-new, flip-top cab opens the machine up wide.



The 200 Series skid steer loader is **BUILT AROUND YOU** and backed by a strong New Holland dealer network that you can count on!

*ISO 5006: 2006 specifies a static test method for determining and evaluating the operator's visibility on a rectangular 1 m boundary close around the machine and on a 12 m visibility test circle.

200
SERIES



A Legacy of Dump Height, Reach, Productivity and Stability

While the 200 Series skid steer loaders have been redesigned from the ground up, they honor New Holland's rich history in the skid steer market. They also have kept the core design characteristics that made New Holland skid steer loaders so productive.

The Heritage Of New Holland: Handle Bigger Loads and Move 'Em Faster

200 Series skid steer loaders provide the best stability and superior visibility, allowing operators to move bigger loads and work with a new level of confidence.

*National ad appeared in Successful Farming,
Machinery Management Issue, February 1980.*

**See how much better
a loader can be.**



"I used to think they were all alike. Now I know better. Wait till you try this one."

Choose from six models, from 22 hp. to 62 hp., gas or diesel. All models feature quick-on attachments you can securely "inside" the machine when you consider the low center of gravity. You'll understand why Sperry New Holland skid-steer loaders are fast becoming known for their stability.

There's more you'll notice. Great maneuverability in tight service areas. Boom lift drive. As the boom rises, it thrusts forward, doesn't arc back toward the operator. Result: extra-long reach so you can dump into places others can't (the center of a big, tandem-axle spreader, for instance).

You'll also notice the operator is positioned

SPERRY NEW HOLLAND

Super Boom®: The best dump height, reach and stability... yesterday, today and tomorrow

The New Holland L35 was the first Vertical Lift Skid Steer Loader in 1972

The New Holland L35 was introduced in 1972, the first vertical lift skid steer, equipped with the patented Super Boom lift linkage. Since then, over 200,000 New Holland Super Boom skid steer loaders have been sold. Today, the New Holland skid steer is built in Wichita, Kansas and is distributed to over 100 countries in the world. New Holland proudly continues the Super Boom tradition with the 200 Series skid steer loader.

As the boom rises, it thrusts forward, and doesn't arc back towards the operator. Result: extra-long height and reach so you can dump into places others can't (the center of a big high-sided truck or tandem-axle spreader, for example). New Holland skid steers provide a seat with a low center of gravity, keeping the operator low and secure in the machine. And when you consider that New Holland offers the longest wheelbase in the industry, you understand why New Holland skid steer loaders are known for their outstanding stability.



ter

change without leaving the cab.
machine, down low. And
longer wheelbase, you
New Holland loaders
for their outstanding
like, too. Hydrostatic
stability. Easy-to-reach
locks for added safety.
loaders are alike, see your
dealer. He'll show you
loader can be.
Division of Sperry Corporation.

SEE How Much Better a Loader Can Be

Visibility is very important to operators and New Holland understands. All-around visibility is delivered with the 200 Series—to the cutting edge, to the bucket at full height, to the sides, and to the rear. You'll complete jobs quickly and efficiently with this skid steer loader.

All-Around Visibility

- The threshold for the front door on the 200 Series has been lowered, allowing for even better sightlines to the loader bucket and to the trench.
- The see-through area on the cab roof provides a clear view to the bucket at full height.
- The tough side screens on the all-new 200 Series are thinner than the previous 100 Series. The result: more than twice the visibility in critical zones (as defined by ISO 5006).



100 Series cab



200 Series cab

- The rear visibility is improved on the 200 Series skid steer with the relocation of the HVAC unit that was mounted at the top of the window. Now, rear visibility is the best in the industry by providing a large rear window, low engine hood and no rear frame towers.



Comfortable, Clean, and Quiet Environment

- A huge glass door opens wide for easy entry and exit. When closed, it provides superior visibility to all corners and creates an open, uncluttered sense of space.
- A heater/defroster kit and optional air conditioning allows you to control the climate in any weather.
- Full-covering, noise-absorbing trim leads to quiet sound levels in enclosed cabs.
- Cab sealing reduces dust infiltration.
- Front lights at the side of the cab expand your forward view, especially to the upper corners, making it easier to position loads overhead and maneuver in low-clearance areas.
- Ample legroom and foot room add to operator comfort.
- A demolition door is available in lieu of a glass door for rugged working conditions.

Other STANDARD features related to visibility:

- Dome light
- Top window
- Alarm package (backup & horn)
- Halogen work lights – two in front and two in back – for longer service life and excellent jobsite visibility
- Pre-wiring for rotating beacon
- Taillights
- Warning lights with alarm (engine coolant temperature, engine oil pressure, air cleaner restriction, hydraulic filter restriction, hydraulic oil temperature)
- Indicator lights (engine preheat, parking break, seat belt reminder)



The full-view front windshield provides an outstanding view while the spacious cab provides a comfortable environment for the operator.

Comfort is Built In

Comfortable operators can work longer hours with less fatigue. The 200 Series New Holland skid steer breaks new ground with industry-leading dimensions, options, and ease of operation.

- lower threshold
- flat floor
- widest cab in the industry

Control Lever Options

Mechanical controls are standard. Electro-hydraulic switchable (ISO-H pattern) controls are optional on models L218 through L230. 200 Series skid steers and compact track loaders built with EH (Electro-Hydraulic) controls feature multiple speed settings on three different circuits: travel, boom and bucket. This allows the customer to personalize the controls depending on their preferences.



Switches are easily accessible on the control handles to operate such items as the horn, left- and right-side proportional auxiliary, glide ride, turn signals, two-speed, float, or attachment multi-function control.



Controls to match your preference

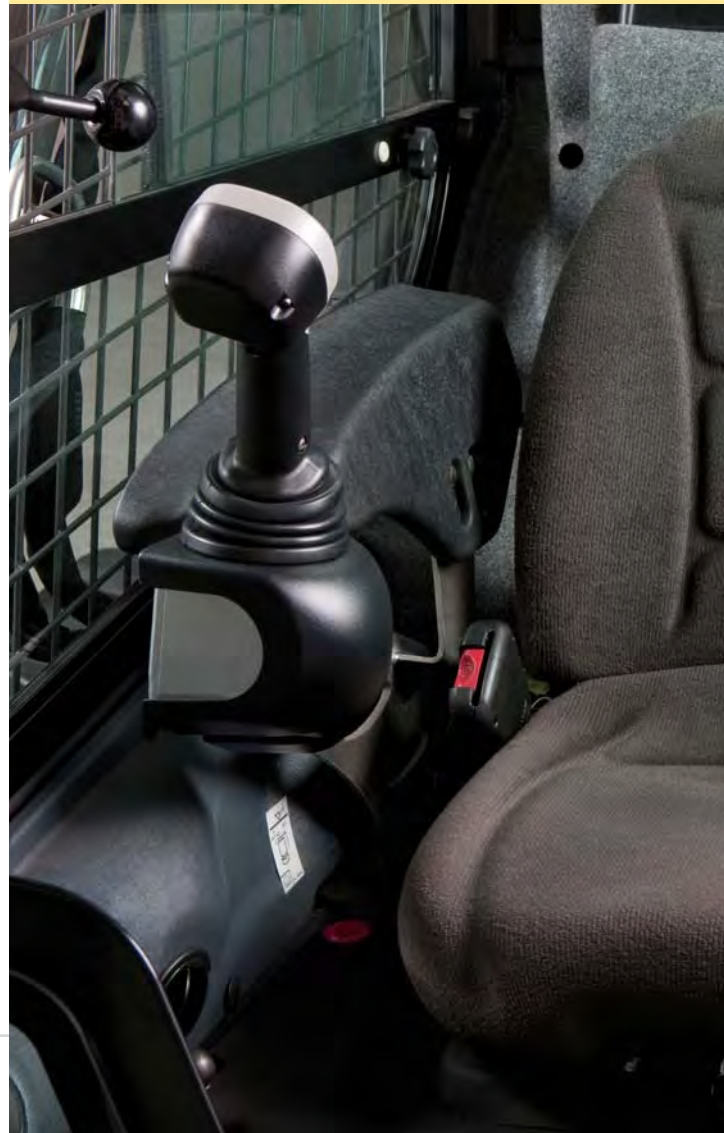



The step floor is flat for easy entry/exit and more foot and leg room.



Cab Comfort

It's easy to enter and exit the 200 Series skid steer loader because the threshold is low, the step area by the foot pedals is flat, and grab handles are positioned for convenient use when getting in and out.

All 200 Series skid steer loaders come standard with a retractable seatbelt (a shoulder belt is standard with enclosed cabs). All models have optional suspension seats or an air-ride cloth suspension seat for the ultimate in comfort.

All the switches and gauges are right in front of you and easy to access from the comfort of your operator seat.

Even more options to customize the operator's environment and increase productivity:

- Enclosed cab with heat and air conditioning
- Hydraulic coupler
- Block heater
- Turn signals
- Self leveling
- Glide Ride
- High-flow hydraulics
- Enhanced high-flow hydraulics (L230)
- Radio with speakers
- Easy-to-remove and clean side windows (no tools required)

Hard Work and Demanding Conditions? BRING IT ON!

Super Boom skid steers are reliable workhorses that stand up to any challenge you face. New 200 Series skid steers are built around you with reliable engines that deliver powerful performance, yet use less fuel and are easy to maintain to decrease your operating costs.



FPT™ F5C Engines (L223, L225, L230)

High Performance in All Conditions

These engines stand out for their low-cost operation, extremely easy maintenance and excellent performance in the most demanding applications.

- These turbocharged engines feature externally cooled EGR (exhaust gas recirculation) for efficient air handling and high engine power density with the shortest load response time.
- A state-of-the-art direct fuel injection system uses a simple, proven, mechanical, rotary pump that provides accurate fuel delivery.
- Operators will notice a minimum of noise and vibration due to the design of the engine, including camshaft in crankcase, suspended oil pan, and balancer counterweights incorporated in crankshaft webs.
- Highly integrated engine components mean superior leakage prevention. Examples include the integrated Closed Crankcase Ventilation (CCV) system and the water-oil cooler, oil and water pumps with by-pass, which are all fully integrated in the block.
- Optimized engine structure, including precise mechanical clearances, piston rings oil system calculations, and a long, 500-hour oil change interval reduces maintenance needs and operating costs.





Optional high-flow hydraulics are available on the L218, L220, L223, L225 and L230.



ISM Engines (L213, L215, L218, L220)

Clean, Compact, Quiet and Easy to Service

- The combustion chamber and injection system use fuel efficiently and deliver outstanding power rise and torque.
- Low emissions and an energy-saving design make these engines as friendly to the environment as they are to your budget.
- The rigid cylinder block, small bore dimension and multiple cylinders lead to low noise and vibration—from idling up to maximum power—for added comfort and ease for operators.
- The compact, well-balanced engine is strong and durable. Its multi-level design also allows for simple parts interchangeability.
- One-sided daily maintenance layout allows for quick servicing activities.
- 500-hour service intervals (250 hours for L213/L215) decrease your operating costs, and maintenance downtime.

All Weather Performance

- Standard glow plugs.
- Standard easy-access, maintenance-free battery with up to 1,000 cold cranking amps.
- Reliable starter for easy starts
- Heavy-duty top and bottom oil cooler/radiator configuration for high cooling capacity under the most extreme conditions. Rigid mount reduces vibration and easy tilt-out for simple cleaning.



Responsive Hydraulics

- Fast cycle times.
- In-line hydraulic pumps produce less noise and provide extra-smooth, quiet operation.
- Optional high-flow hydraulics (on the L218 through L223) allow you to run attachments hour after hour.
- Enhanced high-flow hydraulics are available on the L230.
- The SAHR (Spring Applied Hydraulic Release) parking brake can be released or applied by the press of a button and is automatically applied when machine is shut off.

Extra Performance

- The dual-range transmission can provide travel speeds in excess of 11 mph to save time on and between job sites. It is standard on the L220, L225 and L230

Easy Access Serviceability

New Holland “gets it”: If service access is not easy, it won’t get done. New Holland groups daily service points for easy access. And all major service points can easily be reached by flipping the cab forward.

Service Made Easy

- The rear door and hood provide easy service access for periodic maintenance and daily checkpoints (engine oil, fuel fill, hydraulic oil, coolant and radiator points may be accessed without tools).
- The radiator can be cleaned from both sides.

Service Intervals

- Every 500 hours (L218, L220, L223, L225, L230); 250 hours (L213, L1215) – change engine oil and filter
- Every 500 hours – change primary fuel filters and hydraulic oil filters
- Every 1,000 hours – radiator drain and flush
- Spend more time on the job and less time in the shop for routine maintenance.

Built to last

- New Holland combined elements from the previous skid steer loader boom design with proven technology from larger New Holland loaders to develop a new, superior boom design for the 200 Series.

Operator Features

- Unique dual boom lock struts, when engaged, keep the boom in the raised position (vertical lift models).
- Operators engage and disengage the boom lock without leaving the cab (vertical lift models).
- Rear door louvers direct air flow up, reducing fan noise and air blast to the operator and bystanders.

Unmatched access

If ever needed, the entire cab and boom lift assembly can be tilted forward to provide unrivaled access to components.



The operator is able to engage and disengage the boom lock from inside the cab for added safety when exiting the machine with the boom up.



Single-side battery maintenance layout allows for quick service and fast maintenance activities.





The swing-out, rear-access panel provides quick and easy access to check engine oil, hydraulic oil, radiator coolant and fuel fill.

New Holland Construction Equipment is backed with a 1-Year/Unlimited Hour Standard Warranty.



Multi-Task Master

New Holland skid steers do a lot more than lift and load. Take a look at the wide array of attachments and you'll quickly see how the versatility of these machines can make you more productive. These are just some of the available attachments:

- 4 X 1 Bucket
- Angle Broom
- Augers
- Auto Rake
- Backhoes
- Bale Handler
- Bale Spear
- Brush Grapple
- Chipper
- Cold Planer
- Concrete Bucket
- Concrete Claw
- Dozer Blade
- Harley Power Box Rake
- Hopper Broom
- Log Grapple
- Manure Forks
- Manure Scraper
- Pallet Forks
- Pick-Up Broom
- Post Driver
- Post Puller
- Power Side-Discharge Bucket
- Preparator Landscape Rake
- Rock Bucket
- Root Rake
- Rotary Cutter
- Scrap Grapple
- Silage Defacer
- Silt Fence Installer
- Skid Hoe
- Snow Blade
- Snow Bucket
- Snow Blower
- Snow Pusher
- Steel Tracks
- Stump Grinder
- Tiller
- Tree Shovel
- Tree Spade
- Trencher
- Vibratory Roller



Easy Attachment Changes
Whatever you need to do—dig, lift, hammer, trench, plane, mow, sweep, rake or drill—there is a New Holland attachment that will get your work done.



Optional High Flow Auxiliaries shown below.

Auxiliary Pressure Release

A connect under pressure (CUP) hydraulic manifold is standard equipment on all models and allows for easy hook-up of all hydraulic attachments. By pushing on the fitting, you release pressure in both the machine and attachment lines. Lines can now be relieved without wrenches.

- A.** Hydraulic oil return
- B.** Hydraulic oil supply. These fittings slide into manifold and when pressed in, any pressure within the manifold is directed to the hydraulic oil reservoir.
- C.** Drain line that flows to the tank
- D.** Pressure vents

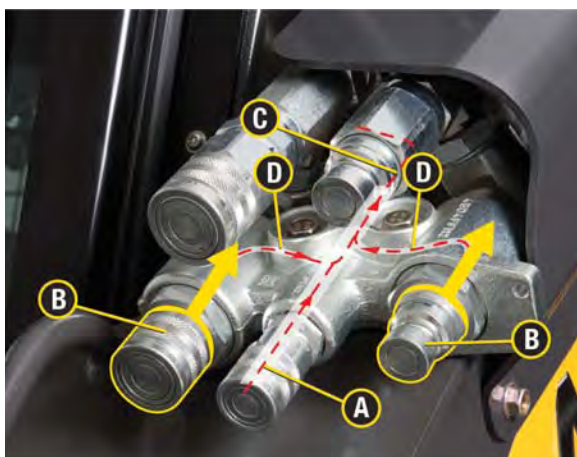

Hydraulic Coupler Option

An optional hydraulic attachment coupler increases uptime and productivity on the jobsite by allowing operators to exchange attachments quickly and safely.



Skid Steer Specifications (Radial Lift)

DIMENSIONS

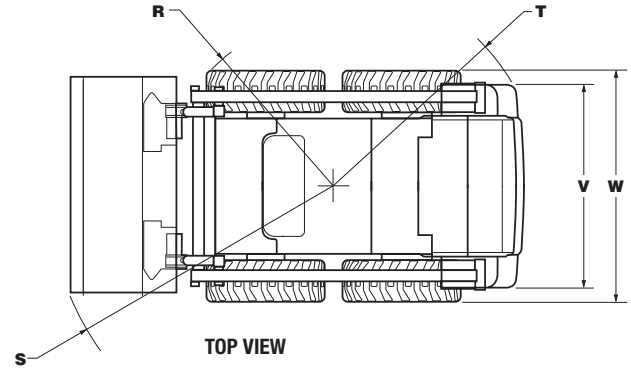
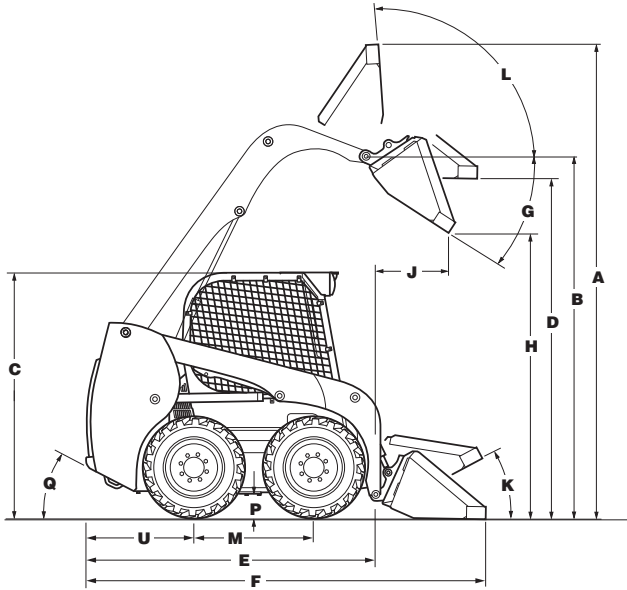

DIMENSIONS	L213	L215
Overall operating height		
A. with foundry/excavating bucket short lip, in (mm)	141.4 (3591)	141.4 (3591)
A. with low profile/standard lip bucket, in (mm)	146.9 (3732)	146.9 (3732)
A. with low profile extended/long lip bucket, in (mm)	152 (3859)	152 (3859)
Height to		
B. Bucket hinge pin, in (mm)	112 (2845)	112 (2845)
C. Top of ROPS, in (mm)	75.5 (1919)	75.5 (1919)
D. Bottom of level bucket, fully raised, in (mm)	105.6 (2682)	105.6 (2682)
Overall length		
E. without attachment with coupler, in (mm)	95.9 (2435)	95.9 (2435)
F. with foundry excavation bucket on ground, in (mm)	119.2 (3028)	119.2 (3028)
F. with low profile bucket, in (mm)	125 (3175)	125 (3175)
F. with low profile extended bucket, in (mm)	129.8 (3297)	129.8 (3297)
Dump		
G. Dump angle, degrees	40	40
H. Dump height		
with foundry/excavating bucket short lip, in (mm)	88.4 (2246)	88.4 (2246)
with low profile/standard lip bucket, in (mm)	84.8 (2154)	84.8 (2154)
J. Dump reach (max height), in (mm)	18.5 (469)	18.5 (469)
Maximum attachment rollback		
K. Bucket on ground, degrees	26	26
L. Bucket at full height, degrees	95	95
Wheelbase and Clearance		
M. Wheelbase, in (mm)	37 (941)	37 (941)
P. Ground clearance (bottom of belly pan), in (mm)	7 (178)	7 (178)
Q. Angle of departure, degrees	22	22
Clearance circle		
R. without bucket, in (mm)	48.7 (1237)	48.7 (1237)
S. with 60" inch foundry bucket in carry position, in (mm)	75.6 (1920)	75.6 (1920)
S. with 60" inch low profile bucket on ground, in (mm)	78.5 (1994)	78.5 (1994)
S. with 60" inch extended low profile on ground, in (mm)	83.1 (2112)	83.1 (2112)
T. Clearance circle rear, in (mm)	56.4 (1433)	56.4 (1433)
U. Rear axle to bumper, in (mm)	33.8 (858)	33.8 (858)
V. Tread width, in (mm)	49.2 (1248) w/10" x 16.5" tires	49.2 (1248) w/10" x 16.5" tires
W. Overall width, in (mm)	59.8 (1518)	59.8 (1518)

Skid Steer Specifications (Radial Lift)

ENGINE	L213	L215
Manufacturer/model	ISM / N844	ISM / N844T
Type	Diesel 4-stroke, I.D.I.	Diesel 4-stroke, T, I.D.I.
Cylinder	4	4
Bore/stroke, in (mm)	3.31 x 3.54 (84 x 90)	3.31 x 3.54 (84 x 90)
Displacement, in ³ (L)	121.7 (2.0)	121.7 (2.0)
Fuel injection	Indirect	Indirect
Fuel	#2 diesel	#2 diesel
Fuel filter	In-line strainer	In-line strainer
Air intake	Naturally aspirated w/ internal EGR	Turbocharged w/ internal EGR
Cooling	Liquid	Liquid
Engine speeds		
High idle - no load, rpm	3140 +/- 50	3140 +/- 50
Rated - full load, rpm	2900	2900
Low idle, rpm	1200 +/-50	1200 +/-50
Horsepower per SAE J1349		
Gross hp (kW)	46 (34) @ 2900 rpm	52 (39) @ 2900 rpm
Net hp (kW)	43 (32) @ 2900 rpm	49 (36) @ 2900 rpm
Peak torque, lb-ft (N•m)	96.3 (130.5) @ 1750 rpm	109 (148) @ 1750 rpm

POWER TRAIN	L213	L215
Drive pump mechanical		
Pump to engine ratio	1:1	1:1
Displacement, in ³ (cc)	2.14 (35)	2.14 (35)
Flow, gpm (Lpm)	26.9 (102)	26.9 (102)
Charge pressure, psi (bar)	363 (25)	363 (25)
System relief, psi (bar)	5000 (345)	5000 (345)
Control	Direct mechanical	Direct mechanical
Drive motors		
Max displacement, in ³ (cc)	19.83 (325)	19.83 (325)
Displacement opt high speed, in ³ (cc)	NA	NA
Speed @ high idle engine rpm	313	313
Speed @ optional high speed, rpm	NA	NA
Torque @ max displ. and relief pressure, lb-ft (N•m)	1316 (1784)	1316 (1784)
Travel speed		
Low range, mph (km/h)	6.7 (10.8)	6.7 (10.8)
High range (optional), mph (km/h)	NA	NA
Final drive	Single-reduction chain drive	Single-reduction chain drive
Drive chain		
Size	ASA #80	ASA #80
Axles		
Diameter, in (mm)	2 (50.8)	2 (50.8)
Length, in (mm)	13.2 (346)	13.2 (346)
Parking brake		
Type	Spring applied, hydraulic release disc	Spring applied, hydraulic release disc
Engagement	Depress on/off brake button on instrument panel, disconnect lapbelt, get off seat, or stop engine	Depress on/off brake button on instrument panel, disconnect lapbelt, get off seat, or stop engine

Skid Steer Specifications (Radial Lift)

HYDRAULIC SYSTEM	L213	L215
Pumps		
Type	Gear	Gear
Displacement standard aux., in ³ (cc)	1.24 (20.4)	1.24 (20.4)
Displacement high flow aux., in ³ (cc)	N/A	N/A
Pump flow, gpm (Lpm)	15.6 (59)	15.6 (59)
Optional high flow, gpm (Lpm)	N/A	N/A
Loader control valve		
Type	3 Spool / open center / series	3 Spool / open center / series
Relief pressure, psi (bar)	3000 (207)	3000 (207)
Hydraulic filter	6 micron / spin on	6 micron / spin on

CYLINDERS	L213	L215
Lift cylinder		
Bore diameter, in (mm)	2.25 (57)	2.25 (57)
Rod diameter, in (mm)	1.375 (35)	1.375 (35)
Stroke, in (mm)	25.4 (645)	25.4 (645)
Closed length, in (mm)	38.9 (989)	38.9 (989)
Bucket cylinders		
Bore diameter, in (mm)	2.25 (57)	2.25 (57)
Rod diameter, in (mm)	1.25 (32)	1.25 (32)
Stroke, in (mm)	14.6 (370)	14.6 (370)
Closed length, in (mm)	23.4 (594)	23.4 (594)

WEIGHTS	L213	L215
Operating weight, lbs (kg)	5070 (2300)	5370 (2436)
Shipping weight, lbs (kg)	4770 (2164)	5070 (2300)

SERVICE CAPACITIES	L213	L215
Fuel tank, gal (L)	16 (60.5)	16 (60.5)
Engine oil with filter, qt (L)	7.9 (7.5)	7.9 (7.5)
Hydraulic system		
Reservoir, gal (L)	4 (15.13)	4 (15.13)
Chain tanks (per side), qt (L)	6.7 (6.3)	6.7 (6.3)

PERFORMANCE SPECS	L213	L215
Rated operating load		
50% tip, lbs (kg)	1300 (590)	1500 (680)
Tipping load, lbs (kg)	2600 (1179)	3000 (1361)
Breakout forces		
Lift cylinder, lbs (kN)	4275 (19)	4275 (19)
Bucket cylinder, lbs (kN)	4150 (18.5)	4150 (18.5)
Cycle times		
Raise, sec	3.4	3.4
Lower, sec	2.1	2.1
Dump, sec	1.9	1.9
Roll back, sec	1.3	1.3

For all Dimensions and Performance Metrics, unless otherwise specified:

L213 – Equipped with 175 lb operator, 60" Dirt & Foundry Bucket and 10 x 16.5 tires

L215 – Equipped with 175 lb operator, 60" Dirt & Foundry Bucket and 10 x 16.5 tires

Super Boom® Skid Steer Specifications (Vertical Lift)

DIMENSIONS

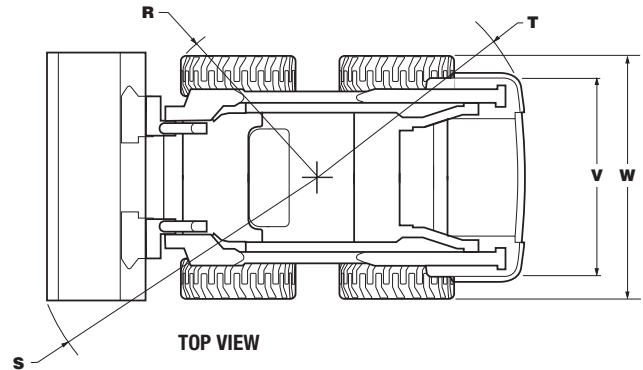
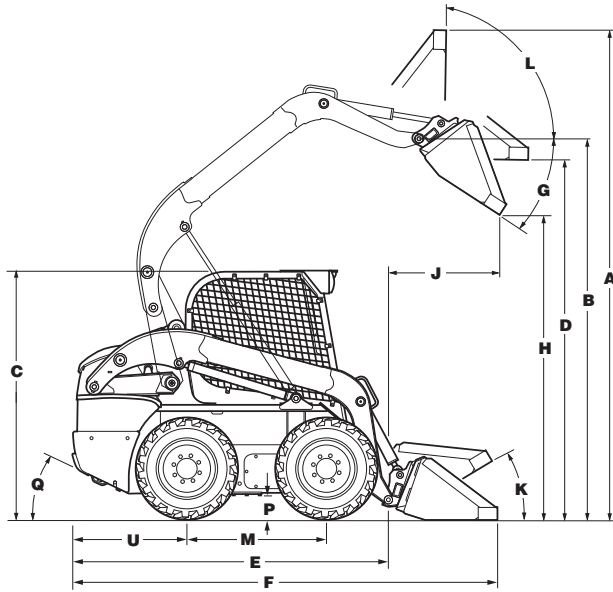

DIMENSIONS	L218	L220	L223	L225	L230
Overall operating height					
A. with foundry/excavating bucket short lip, in (mm)	150.4 (3820)	151.4 (3845)	159.7 (4056)	159.7 (4056)	161.3 (4096)
A. with low profile/standard lip bucket, in (mm)	154.6 (3927)	155.6 (3952)	163.7 (4159)	163.7 (4159)	165.3 (4199)
A. with low profile extended/long lip bucket, in (mm)	159.6 (4055)	160.6 (4080)	168.8 (4287)	168.8 (4287)	170.4 (4327)
Height to					
B. Bucket hinge pin, in (mm)	120 (3048)	121 (3073)	129.5 (3290)	129.5 (3290)	131.1 (3330)
C. Top of ROPS, in (mm)	77.7 (1974)	78.7 (1998)	78.8 (2002)	78.8 (2002)	80.4 (2042)
D. Bottom of level bucket, fully raised, in (mm)	113.3 (2877)	114.3 (2902)	122.6 (3115)	122.6 (3115)	124.2 (3155)
Overall length					
E. without attachment with coupler, in (mm)	106.2 (2697)	105.7 (2685)	117.8 (2993)	117.6 (2986)	117.6 (2986)
F. with foundry excavation bucket on ground, in (mm)	131.9 (3352)	131.4 (3338)	142.9 (3631)	142.7 (3624)	142.7 (3624)
F. with low profile bucket, in (mm)	136.1 (3456)	135.4 (3440)	146.9 (3731)	146.7 (3727)	146.7 (3727)
F. with low profile extended bucket, in (mm)	141.1 (3585)	140.5 (3569)	152.1 (3863)	151.8 (3856)	151.8 (3856)
Dump					
G. Dump angle, degrees	52	52	55	55	55
H. Dump height					
with foundry/excavating bucket short lip, in (mm)	93.6 (2377)	94.5 (2402)	102.9 (2615)	102.9 (2615)	104.5 (2655)
with low profile/standard lip bucket, in (mm)	88.6 (2251)	89.6 (2276)	100.6 (2556)	100.6 (2556)	102.2 (2596)
J. Dump reach (max height), in (mm)	30.8 (783)	29.8 (758)	32.3 (820)	32.3 (820)	30.7 (780)
Maximum attachment rollback					
K. Bucket on ground, degrees	35	34	34	34	33
L. Bucket at full height, degrees	88	88	85	85	85
Wheelbase and Clearance					
M. Wheelbase, in (mm)	44.4 (1128)	44.4 (1128)	52 (1322)	52 (1322)	52 (1322)
P. Ground clearance (bottom of belly pan), in (mm)	7 (178)	8 (203)	8 (203)	8 (203)	9.5 (243)
Q. Angle of departure, degrees	23	25	24	24	27
Clearance circle					
R. without bucket, in (mm)	50.7 (1289)	50.7 (1289)	56.2 (1428)	56.2 (1428)	56.2 (1428)
S. with foundry bucket in carry position, in (mm)	79.6 (2021)	80.9 (2055)	80.3 (2039)	80.3 (2039)	84.8 (2155)
w/66" bucket		w/72" bucket	w/72" bucket	w/72" bucket	w/78" bucket
S. with low profile bucket on ground, in (mm)	83.9 (2132)	84.6 (2150)	87 (2210)	87 (2210)	88.4 (2246)
w/66" bucket		w/72" bucket	w/72" bucket	w/72" bucket	w/78" bucket
S. with extended low profile on ground, in (mm)	88.6 (2250)	89.3 (2268)	91.5 (2323)	91.5 (2323)	92.6 (2352)
w/66" bucket		w/72" bucket	w/72" bucket	w/72" bucket	w/78" bucket
T. Clearance circle rear, in (mm)	63.2 (1606)	62.9 (1599)	70.7 (1796)	70.4 (1789)	70.4 (1789)
U. Rear axle to bumper, in (mm)	36.9 (937)	36.4 (924)	40.7 (1034)	40.7 (1034)	40.7 (1034)
V. Tread width, in (mm)	53.9 (1371)	56.9 (1448)	56.9 (1448)	57.7 (1465)	62.2 (1580)
w/10" x 16.5" tires		w/12" x 16.5" tires	w/12" x 16.5" tires	w/12" x 16.5" tires	w/14" x 17.5" tires
W. Overall width, in (mm)	66.1 (1678)	69.1 (1755)	69.2 (1758)	69.2 (1758)	76 (1930)

Super Boom® Skid Steer Specifications (Vertical Lift)

ENGINE	L218	L220	L223	L225	L230
Manufacturer/model	ISM / N844LT	ISM / N844LT	FPT / F5C E9454	FPT / F5C E9454	FPT / F5C E9454
Type	Diesel 4-stroke, Turbo, I.D.I.	Diesel 4-stroke, Turbo, I.D.I.	Diesel 4-stroke, Turbo, D.I.	Diesel 4-stroke, Turbo, D.I.	Diesel 4-stroke, Turbo, D.I.
Cylinder	4	4	4	4	4
Bore/stroke, in (mm)	3.31 x 3.94 (84 x 100)	3.31 x 3.94 (84 x 100)	3.9 x 4.1 (99 x 104)	3.9 x 4.1 (99 x 104)	3.9 x 4.1 (99 x 104)
Displacement, in ³ (L)	135 (2.2)	135 (2.2)	195 (3.2)	195 (3.2)	195 (3.2)
Fuel injection	Indirect	Indirect	Direct	Direct	Direct
Fuel	#2 diesel	#2 diesel	#2 diesel	#2 diesel	#2 diesel
Fuel filter	In-line w/water separator	In-line w/water separator	In-line w/water separator	In-line w/water separator	In-line w/water separator
Air intake	Turbocharged w/ internal EGR	Turbocharged w/ internal EGR	Turbocharged w/ external EGR	Turbocharged w/ external EGR	Turbocharged w/ external EGR
Cooling	Liquid	Liquid	Liquid	Liquid	Liquid
Engine speeds					
High idle - no load, rpm	3140 +/- 50	3140 +/- 50	2675 +/- 75	2675 +/- 75	2675 +/- 75
Rated - full load, rpm	2900	2900	2500	2500	2500
Low idle, rpm	1200 +/-50	1200 +/-50	1075 +/- 75	1075 +/- 75	1075 +/- 75
Horsepower per SAE J1349					
Gross hp (kW)	60 (45) @ 2900 rpm	60 (45) @ 2900 rpm	74 (55) @ 2500 rpm	82 (61) @ 2500 rpm	90 (67) @ 2500 rpm
Net hp (kW)	57 (42) @ 2900 rpm	57 (42) @ 2900 rpm	68 (51) @ 2500 rpm	76 (57) @ 2500 rpm	84 (63) @ 2500 rpm
Peak torque, lb-ft (N•m)	126 (171) @ 1800 rpm	126 (171) @ 1800 rpm	203 (275) @ 1400 rpm	225 (305) @ 1400 rpm	251 (340) @ 1400 rpm

POWER TRAIN	L218	L220	L223	L225	L230
Drive pump mechanical					
Pump to engine ratio	1:1	1:1	1:1	1:1	1:1
Displacement, in ³ (cc)	2.14 (35)	2.14 (35)	46 (2.81)	46 (2.81)	46 (2.81)
Flow at rated engine rpm @100% eff., gpm (Lpm)	26.9 (102)	26.9 (102)	30.4 (115)	30.4 (115)	30.4 (115)
Charge pressure, psi (bar)	363 (24.5)	363 (24.5)	363 (24.5)	363 (24.5)	363 (24.5)
System relief, psi (bar)	5000 (345)	5000 (345)	5217 (261)	5217 (261)	5217 (261)
Control	Direct mechanical	Direct mechanical	Mechanical servo	Mechanical servo	Mechanical servo
Drive pump electro hydraulic					
Pump to engine ratio	1:1	1:1	1:1	1:1	1:1
Displacement, in ³ (cc)	2.14 (35)	2.14 (35)	2.81 (46)	2.81 (46)	2.81 (46)
Flow, gpm (Lpm)	26.9 (102)	26.9 (102)	30.4 (115)	30.4 (115)	30.4 (115)
Charge pressure, psi (bar)	363 (25)	363 (25)	363 (25)	363 (25)	363 (25)
System relief, psi (bar)	5220 (360)	5220 (360)	5220 (360)	5220 (360)	5220 (360)
Control	Electro hydraulic	Electro hydraulic	Electro hydraulic	Electro hydraulic	Electro hydraulic
Drive motors					
Max displacement, in ³ (cc)	19.83 (325)	19.83 (325)	28.68 (470)	28.68 (470)	28.68 (470)
Displacement opt high speed, in ³ (cc)	12.2 (200)	12.2 (200)	17.21 (282)	17.21 (282)	17.21 (282)
Speed @ high idle engine rpm	313	313	244	244	244
Speed @ optional high speed, rpm	509	509	408	408	408
Torque @ max displ. and relief pressure, lb-ft (N•m)	1316 (1784)	1316 (1784)	1987 (2694)	1987 (2694)	1987 (2694)
Travel speed					
Low range, mph (km/h)	7.4 (11.9)	7.5 (12.1)	7.2 (11.6)	7.2 (11.6)	7.5 (12.1)
High range (optional), mph (km/h)	11.5 (18.5)	11.8 (19)	11.9 (19.2)	11.9 (19.2)	12.2 (19.6)
Final drive	Single-reduction chain drive				
Drive chain					
Size	ASA #80	ASA #80	ASA #100	ASA #100	ASA #100
Axles					
Diameter, in (mm)	2 (50.8)	2 (50.8)	2.44 (61.94)	2.44 (61.94)	2.44 (61.94)
Length, in (mm)	15.1 (384)	15.1 (384)	15.7 (398.7)	15.7 (398.7)	15.7 (398.7)
Parking brake					
Type	Spring applied, hydraulic release disc				
Engagement	Depress on/off brake button on instrument panel, disconnect lapbelt, get off seat, or stop engine				

Super Boom® Skid Steer Specifications (Vertical Lift)

HYDRAULIC SYSTEM	L218	L220	L223	L225	L230
Pumps					
Type	Gear	Gear	Gear	Gear	Gear
Displacement standard aux., in ³ (cc)	1.52 (24.9)	1.52 (24.9)	2.08 (34.1)	2.08 (34.1)	2.08 (34.1)
Displacement high flow aux., in ³ (cc)	.76 (12.5)	.76 (12.5)	1.12 (18.3)	1.12 (18.3)	1.12 (18.3)
Pump flow, gpm (Lpm)	19 (72)	19 (72)	22.5 (85)	22.5 (85)	22.5 (85)
Optional high flow, gpm (Lpm)	28.5 (108)	28.5 (108)	34.6 (131)	34.6 (131)	34.6 (131)
Loader control valve					
Type	3 spool / open center / series				
Relief pressure, psi (bar)	3000 (207)	3000 (207)	3000 (207)	3000 (207)	3000 (207)
Hydraulic filter	6 micron / spin on	6 micron / spin on	6 micron / spin on	6 micron / spin on	6 micron / spin on

CYLINDERS	L218	L220	L223	L225	L230
Lift cylinder					
Bore diameter, in (mm)	2.25 (57)	2.25 (57)	2.5 (64)	2.5 (64)	2.5 (64)
Rod diameter, in (mm)	1.375 (35)	1.375 (35)	1.75 (45)	1.75 (45)	1.75 (45)
Stroke, in (mm)	26.8 (681)	26.8 (681)	33.5 (852)	33.5 (852)	33.5 (852)
Closed length, in (mm)	38.7 (982)	38.7 (982)	46.9 (1192)	46.9 (1192)	46.9 (1192)
Bucket cylinders					
Bore diameter, in (mm)	2.5 (64)	2.75 (70)	3.0 (76)	3.0 (76)	3.0 (76)
Rod diameter, in (mm)	1.375 (35)	1.375 (35)	1.5 (38)	1.5 (38)	1.5 (38)
Stroke, in (mm)	16.1 (410)	16.1 (410)	16.1 (410)	16.1 (410)	16.1 (410)
Closed length, in (mm)	24 (610)	24 (610)	24 (610)	24 (610)	24 (610)

WEIGHTS	L218	L220	L223	L225	L230
Operating weight, lbs (kg)	5930 (2690)	6470 (2935)	7380 (3350)	7900 (3580)	8300 (3765)
Shipping weight, with bucket, lbs (kg)	5630 (2554)	6170 (2799)	7050 (3200)	7565 (3430)	7965 (3610)

SERVICE CAPACITIES	L218	L220	L223	L225	L230
Fuel tank, gal (L)	20 (75.5)	20 (75.5)	25.5 (96.5)	25.5 (96.5)	25.5 (96.5)
Engine oil with filter, qt (L)	8 (8.5)	8 (8.5)	10 (9.5)	10 (9.5)	10 (9.5)
Hydraulic system					
Reservoir, gal (L)	4.3 (16.2)	4.3 (16.2)	6 (22.75)	6 (22.75)	6 (22.75)
Chain tanks (per side), qt (L)	27.5 (26)	27.5 (26)	29.5 (27.9)	29.5 (27.9)	29.5 (27.9)

PERFORMANCE SPECS	L218	L220	L223	L225	L230
Rated operating load					
50% tip, lbs (kg)	1800 (818)	2000 (905)	2250 (1020)	2500 (1135)	3000 (1360)
Tipping load, lbs (kg)	3600 (1632)	4000 (1814)	4500 (2041)	5000 (2268)	6000 (2722)
Breakout forces					
Lift cylinder, lbs (kN)	2740 (12.2)	2615 (11.6)	5090 (22.6)	5090 (22.6)	4940 (22)
Bucket cylinder, lbs (kN)	5435 (24.2)	7145 (31.8)	8585 (38.2)	8585 (38.2)	8585 (38.2)
Cycle times					
Raise, sec	3.0	3.0	3.9	3.9	3.9
Lower, sec	2.4	2.4	2.5	2.5	2.5
Dump, sec	2.2	2.7	2.7	2.7	2.7
Roll back, sec	1.5	2.0	2.0	2.0	2.0

For all Dimensions and Performance Metrics, unless otherwise specified:

L218 – Equipped with 175 lb operator, 66" Dirt & Foundry Bucket with 10 x 16.5 tires
 L220 – Equipped with 175 lb operator, 66" Dirt & Foundry Bucket with 12 x 16.5 tires
 L223 – Equipped with 175 lb operator, 72" Dirt & Foundry Bucket with 12 x 16.5 tires

L225 – Equipped with 175 lb operator, 72" Dirt & Foundry Bucket with 12 x 16.5 tires
 L230 – Equipped with 175 lb operator, 78" Dirt & Foundry Bucket with 14 x 17.5 tires

200 Series Skid Steer Tire Options

SKID STEER TIRE OFFERING		L213	L215	L218	L220	L223	L225	L230
8501207	10 X 16.5 Heavy Duty (59 OTW)	Standard	Standard					
8501507	27 X 10.5 - 15 Premium (64 OTW)	X	X					
8501307	10 X16.5 Premium (59 OTW)	X	X					
8501707	10 X 16.5 Heavy Duty (64 OTW)			Standard	X			
8501807	10 X 16.5 Premium (64 OTW)			X	X			
8501907	10 X 16.5 Premium Liner (64 OTW)			X	X			
8502007	10 X 16.5 Severe Duty (64 OTW)			X	X			
8502107	10 X 16.5 Non- Pneumatic (64 OTW)			X	X			
8503107	12 X 16.5 Heavy Duty (70 OTW)			X	Standard	Standard	Standard	X
8503207	12 X 16.5 Premium (70 OTW)			X	X	X	X	X
8503307	12 X 16.5 Premium-Liner (70 OTW)			X	X	X	X	X
8503407	12 X 16.5 Severe Duty (70 OTW)					X	X	X
8503607	12 X 16.5 Non-Pneumatic (70 OTW)					X	X	X
8505107	14 X 17.5 Premium (76 OTW)					X	X	Standard



200 Series Skid Steer Bucket Options

SKID STEER BUCKETS		L213	L215	L218	L220	L223	L225	L230
Dirt & Foundry Bucket								
60" Dirt & Foundry Bucket	(1524 mm) , 11.5 cu. ft. Heaped Capacity	X	X					
66" Dirt & Foundry Bucket	(1676 mm) , 15.2 cu. ft. Heaped Capacity	X	X	X	X			
72" Dirt & Foundry Bucket	(1829 mm) , 16.7 cu. ft. Heaped Capacity	X	X	X	X	X	X	X
78" Dirt & Foundry Bucket	(1981 mm) , 18.4 cu. ft. Heaped Capacity			X	X	X	X	X
Low Profile Bucket								
60" Low Profile Bucket	(1524 mm) , 11.5 cu. ft. Heaped Capacity	X	X					
Low Profile Extended Bucket								
60" Low Profile Extended	(1524 mm) , 14.3 cu. ft. Heaped Capacity	X	X					
66" Low Profile Extended	(1676 mm) , 15.5 cu. ft. Heaped Capacity	X	X	X	X			
72" Low Profile Extended	(1829 mm) , 17.1 cu. ft. Heaped Capacity	X	X	X	X	X	X	X
78" Low Profile Extended	(1981 mm) , 18.6 cu. ft. Heaped Capacity			X	X	X	X	X
84" Low Profile Extended	(2134 mm) , 20.2 cu. ft. Heaped Capacity			X	X	X	X	X
Light Material Bucket								
60" Light Material Bucket	(1524 mm) , 19.7 cu. ft. Heaped Capacity	X	X					
72" Light Material Bucket	(1829 mm) , 23.7 cu. ft. Heaped Capacity	X	X	X	X	X	X	X
84" Light Material Bucket	(2134 mm) , 27.9 cu. ft. Heaped Capacity			X	X	X	X	X
Manure & Slurry Bucket								
60" Manure-Slurry Bucket	(1524 mm) , 16.7 cu. ft. Heaped Capacity	X	X					
72" Manure-Slurry Bucket	(1829 mm) , 19.1 cu. ft. Heaped Capacity	X	X	X	X	X	X	X
84" Manure-Slurry Bucket	(2134 mm) , 22.5 cu. ft. Heaped Capacity			X	X	X	X	X
Heavy Duty Dirt Bucket								
66" Heavy Duty Dirt Bucket	(1676 mm) , 13.3 cu. ft. Heaped Capacity	X	X	X	X			
72" Heavy Duty Dirt Bucket	(1829 mm) , 14.6 cu. ft. Heaped Capacity			X	X	X	X	X
78" Heavy Duty Dirt Bucket	(1981 mm) , 15.9 cu. ft. Heaped Capacity			X	X	X	X	X
84" Heavy Duty Dirt Bucket	(2134 mm) , 19.4 cu. ft. Heaped Capacity					X	X	X



Heavy Duty
Dirt Bucket



Dirt Foundry
Bucket



Light Material
Bucket



Low Profile
Extended Bucket



Manure &
Slurry Bucket

**200 SERIES
SKID STEER LOADERS**

L213

Horsepower
Gross 46 hp (34 kW)

Operating weight
5,000 lbs (2270 kg)

Rated operating capacity
1,300 lbs (590 kg)

L215

Horsepower
Gross 52 hp (39 kW)

Operating weight
5,300 lbs (2400 kg)

Rated operating capacity
1,500 lbs (680 kg)

L218

Horsepower
Gross 60 hp (45 kW)

Operating weight
5,930 lbs (2690 kg)

Rated operating capacity
1,800 lbs (818 kg)

L220

Horsepower
Gross 60 hp (45 kW)

Operating weight
6,470 lbs (2935 kg)

Rated operating capacity
2,000 lbs (905 kg)

L223

Horsepower
Gross 74 hp (55 kW)

Operating weight
7,380 lbs (3350 kg)

Rated operating capacity
2,250 lbs (1020 kg)

L225

Horsepower
Gross 82 hp (61 kW)

Operating weight
7,900 lbs (3580 kg)

Rated operating capacity
2,500 lbs (1160 kg)

L230

Horsepower
Gross 90 hp (67 kW)

Operating weight
8,300 lbs (3765 kg)

Rated operating capacity
3,000 lbs (1360 kg)



World Class Products Demand World Class Dealers

The purchase of a New Holland machine is just the beginning of our relationship together. Consider your experienced New Holland Construction equipment dealer as your local partner in productivity. Assistance in selecting the right model for your operation and developing an affordable leasing or financing plan through New Holland's financing division, CNH Capital, are just a few advantages your local dealer can provide.

Your New Holland dealer's full service capabilities bring you responsive support with genuine New Holland parts and all makes coverage. More importantly, we are there wherever and whenever you need us with our fully equipped service vehicles. From customized maintenance programs to professional operator and technical training, our factory-trained service and parts experts are there to assist you with any of your equipment support needs.

Your business deserves nothing less than world class product, supported by a world class business partner. That's your New Holland Construction Equipment dealer — your partner in productivity.



New Holland Construction
700 State Street
Racine, WI 53402
866-726-3396 Toll Free
262-636-6011

New Holland Construction Equipment is backed with a 1-Year/Unlimited Hour Standard Warranty.

Design, materials and/or specifications are subject to change without notice and without liability therefor. Specifications are applicable to units sold in Canada, the United States, its territories and possessions, and may vary outside these areas.

© 2011 CNH America LLC. All rights reserved. New Holland is a trademark of CNH America LLC. Any trademarks referred to herein, in association with goods and/or services of companies other than CNH America LLC, are the property of those respective companies.



Safety begins with a thorough understanding of the equipment. Always make sure you and your operators read the Operator's Manual before using the equipment. Pay close attention to all safety and operating decals and never operate machinery without all shields, protective devices and structures in place. This is a one-person machine. Never allow riders in the cab, outside the machine, or in/on any bucket or attachment.

Stock #NHC201109SSLFull • PRINTED IN U.S.A.

Printed on recycled paper